

Aquarius

Free fall OBS with acoustic telemetry

Technical Manual

Document Number: MAN-AQU-0002

Issue D

Designed and manufactured by
Güralp Systems Limited
3 Midas House, Calleva Park
Aldermaston RG7 8EA
England

Table of Contents

1. Preliminary Notes	7
1.1. Proprietary Notice	7
1.2. Warnings, Cautions and Notes	7
1.3. Manuals and Software	7
1.4. Conventions	7
<hr/>	
2. Introduction	9
2.1. Description	9
2.2. Summary of Key Features	9
<hr/>	
3. Getting Started	11
3.1. Unpacking and Packing	11
3.2. System Overview	11
3.2.1. The Aquarius	12
<hr/>	
4. The Aquarius Components	14
4.1. Seismic Sensor	14
4.2. Ultra Low Power Digitiser (ULPD)	14
4.3. Low Power Computer (LPC)	15
4.4. Acoustic Modem	16
4.5. The Battery System	17
4.6. Accessory Devices	17
4.6.1. APG	17
4.6.2. Hydrophone	18
4.7. Keller Pressure Sensor	18
4.8. Buoyancy	18
4.9. Recovery Aids	18
4.10. Ballast and Release System	18
4.11. The Underwater Cable Loom	20

4.12. Connectors on the Aquarius Canister	20
4.13. Lifting Frame	21

5. Battery Charging **22**

5.1. Charger Box	22
5.2. Batteries Charging Specifications	23
5.3. Charging Cable	24
5.4. Charging the Batteries	24
5.4.1. Connecting the Charger	24
5.4.2. Operating the Charger Unit	25
5.5. Checking Battery Status	25

6. OBS Assembly **27**

6.1. OBS Assembly	27
6.1.1. Attach Ballast	27
6.1.2. Assemble Burn-Wire System	30

7. Deck Unit and Surface Dunker **36**

7.1. Deck Unit Block Diagram	36
7.2. Side Connectors Panel	36
7.3. Connect to the ULPD and LPC Consoles	37

8. Configuration via Webpage **38**

8.1. Connect to Aquarius via Discovery Software	38
8.2. Web Interface Overview	39
8.3. Station Metadata Setup	40
8.4. PTP Settings	41
8.5. Acoustic Modem Setup	43
8.6. Low Battery Voltage Thresholds	43
8.7. Streamed Data Setup	44
8.8. Recorded Channels Setup	46

Aquarius Ocean Bottom System

8.8.1. MicroSD Cards Monitoring and Maintenance	48
8.9. Configuration Download	49
8.10. Deploy Mode	50
8.11. Stop Recording and Undeploy	50

9. Discovery Tools **52**

9.1. OBS Command & Control	53
9.1.1. State of Health of the Acoustic Link	54
9.1.2. Acoustic Configuration	55
9.1.3. Post Deployment	57
9.1.4. Trigger Parameters	60
9.1.5. Data	60
9.1.6. Recovery (Ballast Release)	61
9.1.7. Error Messages	63
9.2. Aquarius Deployment	64
9.2.1. System Reset	65
9.2.2. Web Interface	66
9.2.3. Timing	66
9.2.4. Storage	67
9.2.5. Recovery	68
9.2.6. Deployment	70
9.3. Aquarius Localisation	71
9.3.1. Overview	72
9.3.2. Locating Aquarius	72
9.3.3. Data Processing	77
9.3.4. Log Files	83
9.4. Aquarius Recovery	85
9.5. Remote Deck Unit	88

10. Download Recorded Data **89**

10.1.1. Bulk Data Extraction via Network	92
10.1.2. Time Based Data Extraction via Network	92
10.1.3. Metadata	94

11. Appendix A – Channel Names 98

- 11.1. Data Streaming 98
 - 11.2. Data Recording 99
-

12. Appendix B – Connector Pin-Outs 101

- 12.1. OBS – APG/Hydrophone and Burn-Wire 101
 - 12.2. OBS – Ethernet and Serial RS-232 101
 - 12.3. OBS – Battery Charger 102
-

13. Appendix C – Acoustic Modem Link 104

- 13.1. Description of Operation 104
 - 13.1.1. Modem Configuration 104
 - 13.2. Sonardyne Debugger 108
 - 13.3. Troubleshooting 112
 - 13.3.1. Send a Short Command 113
 - 13.3.2. Read Modem Status 115
 - 13.3.3. Get OBS System Information 115
 - 13.3.4. Get Seismic Data 117
-

14. Appendix D – Detailed Checklist 119

- 14.1. OBS Assembly Check 119
 - 14.2. Aquarius Webpage Configuration Checks 120
 - 14.3. Acoustic Communication Checks 121
 - 14.4. Pre-Deployment Checks 121
 - 14.5. Deployment Procedure Check 122
 - 14.6. Post-Deployment Checks 123
 - 14.7. Recovery Procedure Check 123
-

15. Appendix E – Printable Checklist 125

16. Appendix F – Glossary	127
17. Revision history	129

1. Preliminary Notes

1.1. Proprietary Notice

The information in this document is proprietary to Güralp Systems Limited and may be copied or distributed for educational and academic purposes but may not be used commercially without permission.

Whilst every effort is made to ensure the accuracy, completeness and usefulness of the information in the document, neither Güralp Systems Limited nor any employee assumes responsibility or is liable for any incidental or consequential damages resulting from the use of this document.

1.2. Warnings, Cautions and Notes

Warnings, cautions and notes are displayed and defined as follows:

 **Note:** Indicates a procedural or advisory information

 **Caution:** Highlights a condition or action that, if not followed, may result in equipment damage, reduced performance, or loss of data.

 **Warning:** Alerts to a hazard that could result in personal injury or serious damage to the equipment if ignored.

1.3. Manuals and Software

All manuals and software referred to in this document are available from the Güralp Systems website: www.Güralp.com unless otherwise stated.

1.4. Conventions

Throughout this manual, examples are given of command-line interactions. In these examples, a fixed-width typeface will be used:

Example of the fixed-width typeface used.

Commands that you are required to type will be shown in bold:

Example of the fixed-width, bold typeface.

Aquarius Ocean Bottom System

Where data that you type may vary depending on your individual configuration, such as parameters to commands, these data are additionally shown in blue:

Example of the fixed-width, bold, blue typeface.

Putting these together into a single example:

System prompt: **user input with variable parameters**

2. Introduction

Thank-you for purchasing a Güralp Aquarius.

This manual describes the key components of an Aquarius system.

2.1. Description

The Aquarius system is a state-of-the-art ocean bottom seismometer comprising:

- Aquarius

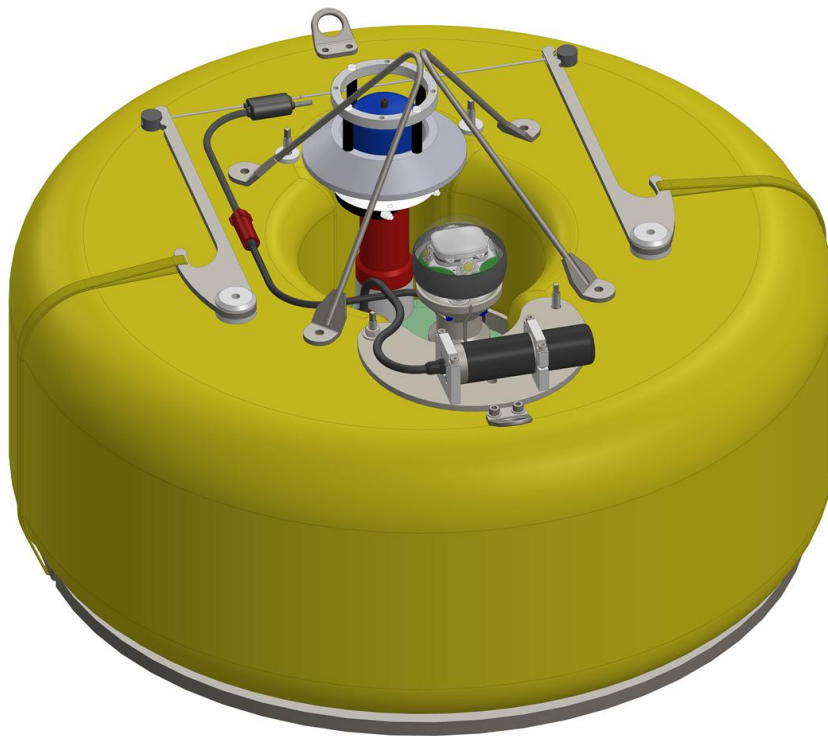

- Güralp Aquarius Deck Unit
- Mini Dunker acoustic modem
- Ethernet and serial cable
- Güralp Aquarius Charger unit with charger cable

2.2. Summary of Key Features

- Compact OBS equipped with an acoustic modem.
- Digital feedback triaxial broadband seismometer, operational at any angle, with a flat response between 120 s and 100 Hz.
- A three-axis magnetometer and a MEMS accelerometer calculates the seismometer's 3D position on the seabed.

Aquarius Ocean Bottom System

- Transmission of sensor data and State of Health parameters from the seabed following installation.
- Up to 9000 bps transmission of data between seabed and surface using acoustic communication.
- Dual redundant 128 GB microSD card.
- Single cable connection to the Güralp deck unit for Gigabit Ethernet data download, system configuration and external power.
- Acoustic Burn-Wire release mechanism with satellite tracking system.
- Operational depth 6000 meters.

3. Getting Started

3.1. Unpacking and Packing

The Aquarius OBS is delivered in an environmentally-friendly, flat-packable, suspension packaging. The packaging is specifically designed for the Aquarius system and should be re-used whenever you need to transport the sensor. Please note any damage to the packaging when you receive the equipment and unpack on a clean surface.



Caution: The Aquarius OBS contains sensitive mechanical components which can be damaged by mishandling. If you are at all unsure about the handling or installation of the device, you should contact Güralp Systems for assistance.

- Do not bump or jolt any part of the equipment when handling or unpacking.
- Do not kink or walk on the data cable (especially on rough surfaces such as gravel), nor allow it to bear the weight of the sensor.
- Do not connect the instrument to power sources except where instructed.
- Never ground any of the output signal lines from the sensor.



Warning: The Aquarius OBS with ballast weighs around 350 kg in air and 26 kg in water. Improper storage or handling may cause injury, disability or death. Always follow recognised safety procedures for heavy equipment handling.

3.2. System Overview

The heart of the system is the Aquarius Ocean Bottom Seismometer (OBS) unit, deployed on the seabed. This is a battery powered triaxial seismometer with ancillary multi-parametric sensors and datalogger. The unit may be additionally supplied with an absolute pressure gauge or a hydrophone. The Aquarius is equipped with an acoustic modem to provide data telemetry and status information to the surface and it is designed for deployments on the seabed of the duration of over a year and with a working depth of 6000m. Also included are satellite tracker and LED strobe to aid location during recovery.

During deployment and recovery operations, it is possible to control and configure the Aquarius or offload the data using a PC or the Güralp waterproof deck unit. The Güralp deck unit can also be connected to a surface dunker acoustic modem providing data telemetry to the deck with the Aquarius in the water. Being equipped with lithium-ion batteries, the Güralp deck unit can be operated on deck without the use of any mains electricity supply.

The Aquarius battery can be re-charged using the charger unit provided with the system.

3.2.1. The Aquarius

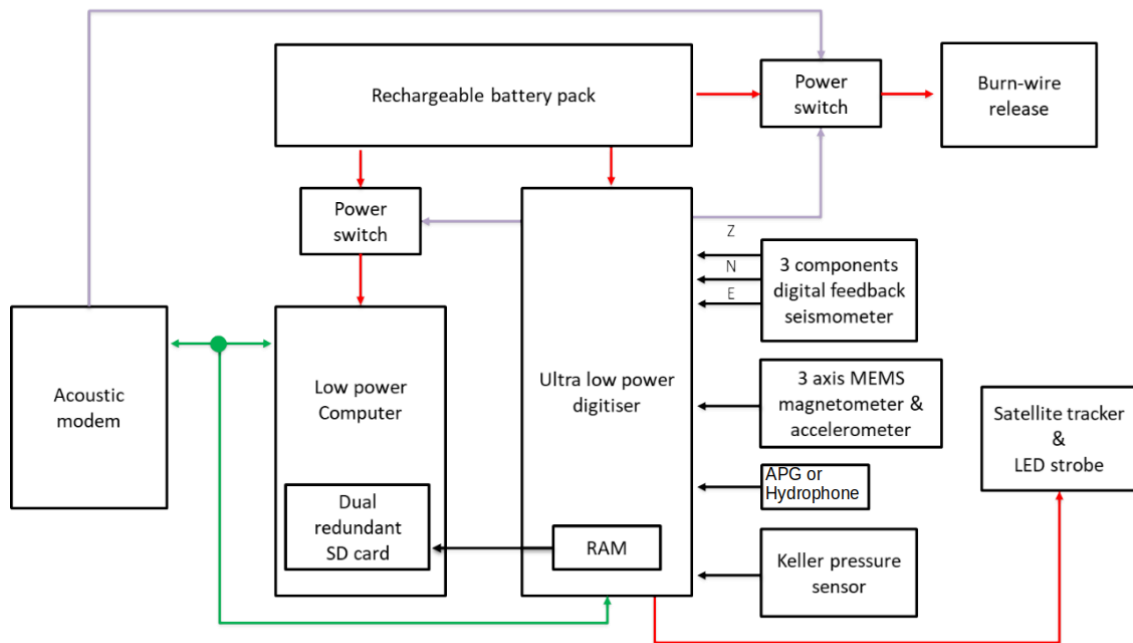

The Aquarius is the sea-floor unit of the system. It includes a weak motion triaxial digital broadband velocity seismometer, which is operational at any angle, without the need of any gimbals system. A three-axis magnetometer and a MEMS accelerometer allow calculation of the main sensor's 3D position on the seabed.

Additional sensors included are: a Keller piezoresistive pressure transducer, used to measure the depth of the OBS and to automatically turn on the recovery aids when the system is rising back to the surface. Optionally the Aquarius may also include a Paroscientific Absolute Pressure Gauge (APG) used to measure accurate water column pressure variations or an ultra-low frequency pressure compensated hydrophone.

All the sensors transmit data to an Ultra Low Power Digitiser (ULPD), which monitors and controls the system. The ULPD is always running when power is provided. Seismic and environmental data is temporally stored in the volatile memory (RAM) of the ULPD and flushed into the dual redundant Micro SD cards of a Low-Power Computer (LPC) every 45 minutes.

The LPC is mainly powered off and it can be waken up using the power switch activated by the ULPD when a data flush is needed or in case of activity of the integrated acoustic modem, for more details see Section 4.3.

The acoustic modem with directional or omni-directional transducer is installed to communicate with the deck unit during deployment and recovery. Most of the time the

Aquarius Ocean Bottom System

acoustic modem is in sleep mode and wakes up when it receives an acoustic wakeup signal or when receiving data from the LPC serial.

The OBS is powered by rechargeable lithium-ion batteries sized to last for up to 18-months deployment.

The Burn-Wire release system can be activated either by the acoustic modem when receiving the related release command, or by a timer in the ULPD.

The ULPD also controls the satellite tracking system and the LED strobe, which are activated during the recovery procedure.

4. The Aquarius Components

4.1. Seismic Sensor

The seismometer installed in the Aquarius is a weak motion orthogonal three-axis digital feedback broadband velocity sensor, with flat response between 120 s and 100 Hz and sensitivity equivalent to an analogue 2000 V/m/s sensor. The seismometer is operational at any angle, without the need of any gimbals, thus guaranteeing the end user the ability to record good data whichever way the OBS lands on the seabed. A three-axis magnetometer and a MEMS accelerometer are also included to allow calculation of the seismometer's 3D position on the seabed, allowing the end user to rotate the signals in post-processing.



Note: Raw data from the MEMS and from the magnetometer are sent to the surface only when a "Status" is requested from the surface via acoustic modem. These data are not stored in the SD card.

The seismometer is located at the bottom of the central part of the low-profile pressure canister for best coupling with the seabed sediments.

The components of the Aquarius seismometer do not need to be locked during transportation and deployment. The sensor will auto-centre the three components. If centring operation fails, the unit will wait and retry after a time interval. The time interval will double every time it fails to centre.

4.2. Ultra Low Power Digitiser (ULPD)

The core of the OBS is a 5-channel Ultra Low Power Digitiser (ULPD). With 24-bit resolution, it monitors and controls the systems including power distribution and storage of data, so it is always running when power is connected.

Three channels of the digitizer are used for the three components of the seismic sensor, a fourth for the (optional) hydrophone or APG and the fifth channel is used for the Keller pressure sensor.

The ULPD has three main states:

- Undeployed
- Deployed and Recording
- Deployed Without Recording.

Undeployed

The ULPD is in the **Undeployed** state only after a power cycle (when the off plug is removed, see Section 4.12) or after a system reset (see Section 9.2.1). In this state the system is in high power mode and is synchronising the clock with PTP.

Deployed and Recording

Just before a deployment the user will have to bring the ULPD to the **Deployed and Recording** state (see Section 9.2). In this state the system will be in low power mode and the clock is free running.



Note: The ULPD clock is a double temperature compensated VCXO. At stable temperature is expected to drift less than a millisecond per day.

The Aquarius starts recording the channels configured prior to deployment in the volatile memory (RAM) of the ULPD, and will shut down the LPC. To optimize the power consumption, all the recorded channels have a fixed sample rate and are called FR (Fixed Recording), see Section 8.8. The ULPD boots up the LPC every 45 minutes to allow an offload of data from the RAM to the microSD cards. After this, the ULPD will power off the LPC.

The ULPD will also calculate the STA, the LTA and their ratio stream. If required, a threshold trigger can be set on the ratio stream to force a data offload to the LPC when an event is detected.

Deployed Without Recording

After the recovery the ULPD can be set to the **Deployed without recording** state following the procedure described in Section 8.11. In this state the system will be in high power mode, but clock synchronising is disabled to allow calculation of the time offset post-deployment (more details in next section).

Another function of the ULPD is the monitoring of the acoustic modem output. This is used to turn on the LPC when data is received through the modem, allowing it to manage the acoustic communication. The acoustic system is responsible for the activation of the Burn-Wire release system. However, a timer can also be set in the ULPD to activate the release system in the unlikely event that acoustic communication fails. This is usually used as a back-up option.

The ULPD also monitors the PoE power supply: when PoE is applied to the system, the LPC will boot up or re-boot, in full power mode with the LAN enabled.

The ULPD is equipped with a triaxial Micro Electro-Mechanical Systems (MEMS) accelerometer with a measurement range of ± 2 g, and a magnetometer. These are used to calculate the orientation of the Aquarius when it is on the seabed.

When the OBS is on the surface, serial console access to the ULPD is provided through the SubConn 13-way connector on the top of the Aquarius canister (see Section 12.2).

4.3. Low Power Computer (LPC)

The main computer in the unit is a Güralp Minimus, configured as an Aquarius. The operation principles of the Low Power Computer (LPC) are largely identical to that of a Minimus-based device: please refer to the Güralp Minimus firmware manual ([MAN-DIG-0001](#)) for non-OBS specific topics outside of this document.

Aquarius Ocean Bottom System

The LPC has a significantly more powerful processor and higher power consumption than the ULPD; therefore, the LPC is powered off by the ULPD when not required.

The LPC will boot up in different modes when power is provided, depending on the ULPD state.

- When the ULPD is **Undeployed**, the LPC will boot up in full power mode with the LAN enabled.
- If the ULPC is either in **Deployed and Recording** state or in **Deployed Without Recording** state, the LPC will boot in low power mode with the LAN disabled. The LPC web server will be accessible only by turning on the PoE.
- Enabling PoE, regardless of the ULPC state, triggers a reboot of the LPC with LAN enabled.

The LPC firmware controls acoustic communication and performs operations requested through acoustic commands transmitted from the surface via the Discovery software. When the LPC is powered off, the ULPD automatically powers it on upon detection of acoustic data transmission.

When the LPC is first powered on, it is in a **Pre-Deployment** mode, in which the LAN is enabled, recording is disabled, and the system attempts to obtain a time lock from the PTP time server. Once the LPC is synchronised via PTP, the time is forwarded to the ULPD.

In **Deployed** mode, the LPC is shut down and periodically woken every 45 minutes in low-power mode with the LAN disabled to allow data offload.

Upon recovery, the system must be powered via PoE to reboot the LPC in normal power mode with the LAN enabled, while the ULPD remains in the deployed state. In this condition, the LPC synchronises to PTP while the ULPD's clock operates free running. Once the ULP PTP stability approaches 100%, the time offset between the ULPD and LPC should be noted down.

After the time offset has been recorded, a system reset will bring the system to its **Undeployed** state.



Note: Undeploying the system will reboot both LPC and ULPD without saving the time offset. Make sure you take note of this before performing a system reset.

When the OBS is on the surface, serial console access to the LPC is provided through the SubConn 13-way connector on the top of the Aquarius canister (see Section 12.2).

4.4. Acoustic Modem

The Aquarius is equipped with a directional or omni-directional acoustic modem to communicate with the deck unit during deployment and recovery. Most of the time the acoustic modem will be in sleep mode using very little power. The modem will change to

listen mode when it receives a wakeup signal acoustically or from the OBS. The modem will go back to sleep mode after 4 minutes of inactivity.

In sleep mode the modem has a nominal power consumption of 7.4 mW and it is powered by 2S batteries (see Section 4.5). When it is awake the input voltage range is 11-16.8 V and it is powered at 14 V by the built-in power board installed in the Aquarius. The acoustic modem has a slant range > 8,000 m (typically 10,000 m) and it uses a Lower Medium Frequency (LMF) rated for operations up to 6000 m depth.

The acoustic modem can directly control the Burn-Wire for the ballast release and it is activated by the 14 V supply.

4.5. The Battery System

The unit is equipped with rechargeable lithium-ion batteries sized for a 18-month deployment. Recharge time is approximately 1-hour charge for 1-month deployment.

The batteries are arranged in groups of 39 cells, connected in parallel, referred to as a 1S. Each cell has a nominal capacity when fully charged of 3.5 Ah. When flat, the batteries will be at 2.5 V, rising up to 4.25 V when fully charged.

Within the OBS there are 6 compartments, each of which contains a battery pack. This battery pack is referred to as a 2S, as it is composed by 2 x 1S packs connected together in series.

The battery packs are connected back to the system as individual units to allow greater flexibility and to allow each 1S to be monitored independently, when charging. See Section 5 for details about the charging process.

The total capacity of the 6 x S2 packs (468 cells total) is 819 Ah @ 7.27 V nominal. The overall energy stored in the full pack of batteries is 5954.13 Wh.



Caution: Lithium-ion batteries can explode violently if incorrectly charged. Use only the supplied charging equipment and always follow the instructions when charging.



Caution: Air transport safety regulations limit the maximum battery wattage allowed when travelling on a passenger plane to 100 Wh, making it illegal to transport these batteries on a passenger flight.

4.6. Accessory Devices

4.6.1. APG

The Aquarius may be fitted with an 8CB4000-I Paroscientific Absolute Pressure Gauge (APG) with 400 bar full scale and 0.01% accuracy. Resolution can go up to 10^{-8} (nano-

Aquarius Ocean Bottom System

resolution), but in order to reduce its power consumption, the APG has been set to work in standard mode (parts per million resolution). The APG provides the ultimate precision in water level measurements and is ideal for applications such as tsunami detection, wave and tide gauges or as accurate depth sensor.

The APG is connected via RS-232 serial interface to the ULPD that records its data at a fixed sample rate of 5 sps.

4.6.2. Hydrophone

The Aquarius may be fitted with a HTI-04-PCA / ULF hydrophone with a 0.01 Hz to 8 kHz frequency response and -194 dB (1 V/ μ Pa) sensitivity.

The hydrophone is connected to the ULPD, which digitises and records its data at a fixed sample rate of 100 sps.

4.7. Keller Pressure Sensor

The Aquarius is fitted with a piezoresistive pressure transducer type Keller PA-10L with full scale 400bar and has an accuracy of 0.25%. The transducer can resolve water depth to 0.1 m.

This sensor is used to calculate the depth of the OBS when a “status” is requested via acoustic link and it is also used to automatically turn on the recovery aids when the instruments come back to the surface.

4.8. Buoyancy

The buoyancy of the Aquarius is provided by a syntactic foam block and allows it to come back to the surface when the ballast is released. The circular buoyancy block is placed over the Aquarius canister, with a central hole allowing access to the top of the sensor canister. The buoyancy is painted Signal Yellow to aid visibility.

4.9. Recovery Aids

The Aquarius is usually supplied with a third-party recovery aid system. A popular choice is the Apollo beacon, manufactured by **Xeos Technologies**. The Apollo beacon is a satellite GPS recovery beacon. Some models or system configurations also provide an integrated LED strobe for visual location once the instrument has surfaced. For more information, please refer to the Xeos website available at the link below:

<https://xeostech.com/introducing-apollo-x>.

4.10. Ballast and Release System

The ballast for the Aquarius is provided by a double-layer steel ring attached to the bottom of the Aquarius. The ballast is suspended from the Aquarius by two straps, one either side,

Aquarius Ocean Bottom System

which are held in tension by two arms on the top of the unit. These arms are held together by a single Burn-Wire.

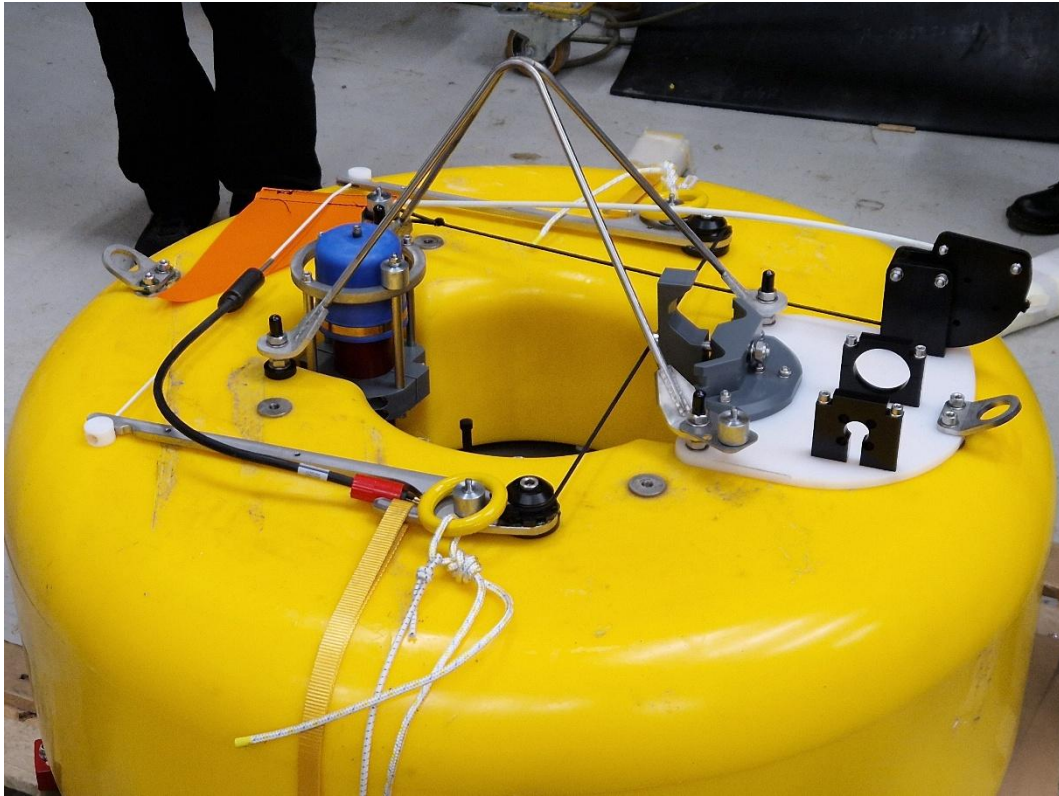

To release the unit a current is passed between the Burn-Wire and a cathode, causing the Burn-Wire to corrode rapidly, thus breaking and releasing the unit. When the Burn-Wire has broken the unit will float to the surface thanks to the lifting force provided by the syntactic foam block.

The Burn-Wire release can be activated either by the acoustic modem or by the timer set in the ULPD. When the modem sends the command, the power to burn the wires is provided by the same switching supply used to power the acoustic modem and providing 14V. In this scenario, it takes approximately 10 minutes for the wire to break. In the other case, when the ULPD activates the sequence, only a 2S batteries voltage is sent to the Burn-Wire system and the release takes around 20 minutes. This time, being related to the voltage provided to the Burn-Wire system, will depend on the State of Charge of the batteries.

4.11. The Underwater Cable Loom



The underwater cable loom is composed by 3 cables and it is used to connect an accessory device (APG or hydrophone) to the Aquarius canister and also to activate the Burn-Wire.

A 2-way Subconn connector provides power to the Burn-Wire.

If fitted, a Burton 8-way connector is used to connect the APG sensor and it provides power and serial communication to the digital pressure sensor.

Alternatively, and if fitted, a 4-way Subconn connector provides signal and power connections to the hydrophone.

The 8-way Subconn Micro series connector is connected to the Aquarius canister.

4.12. Connectors on the Aquarius Canister

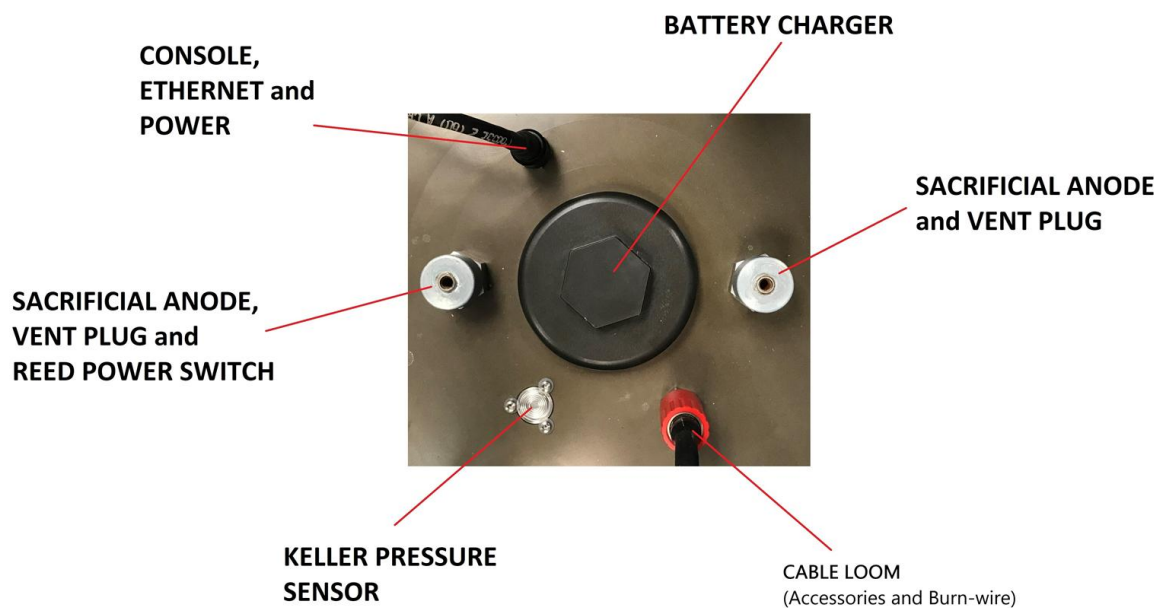

Aquarius Ocean Bottom System

On the top half of the Aquarius canister the end user can identify the following parts:

- **Battery charger port:** used to recharge the lithium-ion batteries housed inside the canister before any deployment (see Section 12.3).
- **Cable Loom:** used to power and communicate with the APG sensor or Hydrophone, and to activate the Burn-Wire (see Section 12.1).
- **Keller pressure sensor.**
- **Console, Ethernet and Power connector:** used to connect to the ULPD and LPC consoles, to access the LPC webpage and other functionalities via Ethernet and to eventually power up the system using an ROV compatible marine cable (see Section 12.2).
- **Sacrificial anode and vent plug.**
- **Reed power switch:** used to power off the system with an off plug during periods of storage and transport.

The system should be powered off using the off plug when it is not used to ensure the batteries are not drained while the unit is being transported or if the unit is put into storage for any length of time. The plug can also be used to reset the unit.



Note: The batteries can be charged when the off plug is inserted and the system powered off.



Note: The reed switch connector is located between the Keller pressure sensor and the SubConn 13-way connector the underwater cable loom.

4.13. Lifting Frame

For deployment and recovery, the Aquarius can be lifted using the stainless-steel frame shown in the picture on the side.

The frame is attached to the top of four stainless steel rods. On the bottom side, the rods are attached to the flange of the Aquarius aluminium pressure canister.

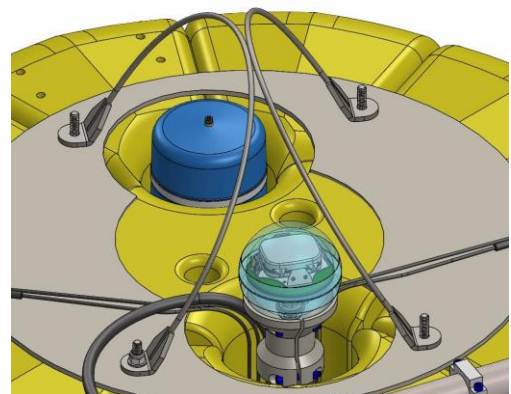

5. Battery Charging

5.1. Charger Box

The charger unit has been designed in conjunction with the OBS battery packs, so that it can charge the batteries in the shortest time possible. As mentioned in Section 4.5, there are 12 x 1S battery packs in the OBS and, for the charging, they are connected as three packs with 4S configuration. Each 4S pack has its own charger circuit, this allows to charge all cells in the Aquarius in a third of the time. The chargers monitor temperature, voltage and current of each 1S battery pack during the charging cycle.

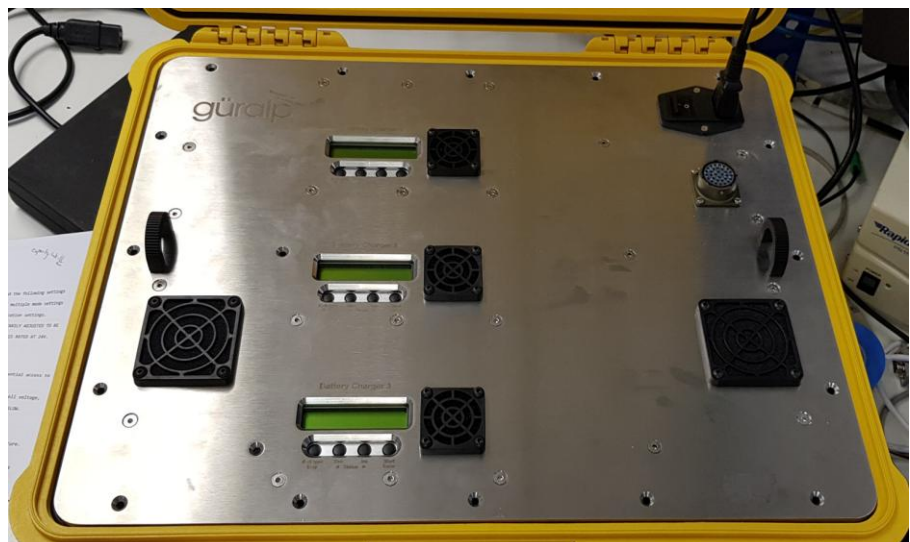

Therefore, three battery chargers were installed in the charger unit, all three are connected to the OBS unit through the same cable described in Section 5.3. The charger unit voltage input is 85 V to 230 V AC.

Aquarius Ocean Bottom System

Each of the chargers is equipped with a display and 4 control buttons:

- Batt type / Stop
- Dec / Status Decrement
- Inc / Status Increment
- Start / Enter



The charger unit is built into a Peli case so when properly sealed it is fully waterproof (IP67).



Warning: The charger unit is not waterproof when the lid is open. To dissipate the heat generated during the charging process, the unit was designed with ventilation fans and an outlet port.

Do not allow water into the unit when the lid is open.

5.2. Batteries Charging Specifications

Parameter	Value
Batteries arrangement	4S
Nominal voltage per cell	4.2 V
Maximum charging voltage per 4S pack	16.8 V
Max charging current	15 A

5.3. Charging Cable

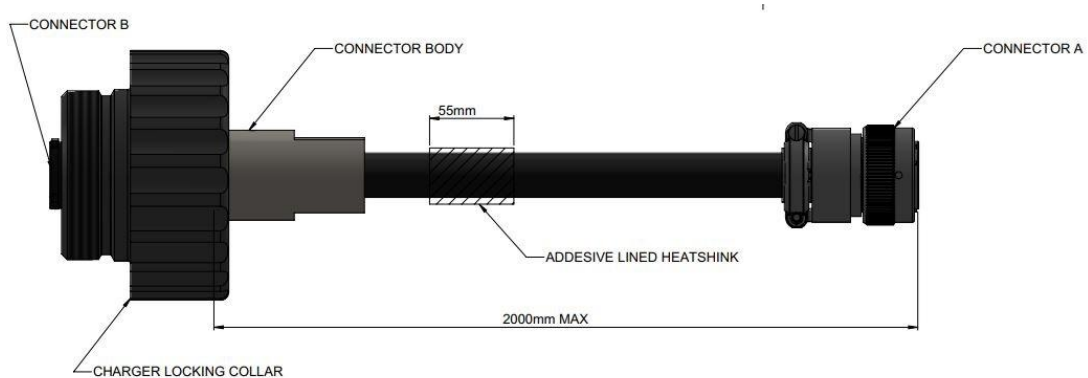

A 2.5 m charging cable, specifically designed for charging the Aquarius has been provided with the system. The cable has a 32-way MIL-spec connector on both ends, socket on the Aquarius canister side and plug on the charger unit side.

For details about the pin-out see Section 12.3.

The cable has a locking collar on the Aquarius end. When this is screwed down with the O-ring in place, the Aquarius canister will still be waterproof, allowing charge of the OBS under rain or sea salt sprays.

As warned in the previous paragraph, the charger unit will need to be sheltered while charging.

5.4. Charging the Batteries

5.4.1. Connecting the Charger

Using the special tool provided, undo and remove the cap in the centre of the OBS to reveal the charging connector.



Caution: It is important to use the tool provided to avoid damage to the protecting finish on the cap and cause corrosion.

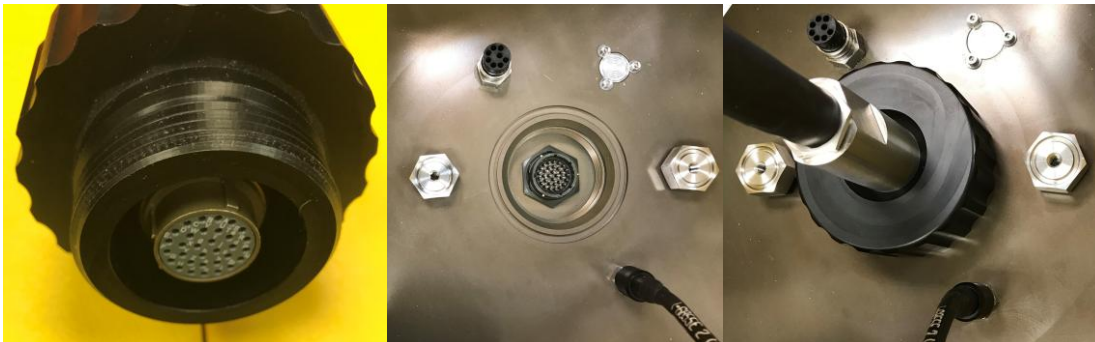

The cable connector with the large black ring connects to the OBS canister. Check the alignment as the connector is pushed in and tightened by hand.

5.4.2. Operating the Charger Unit

Batteries should be charged according to the following steps:



Note: Points 3 to 8 of the procedure above is required only if the battery charger loses its configuration. When the charger is switched off it maintains the configuration. Before shipment, the chargers are programmed with the correct settings. If no changes are applied to the original settings, you should execute steps 1 and 2, and then jump to step 9.

1. Connect the cable as described in Section 5.4.1.
2. Power up the charger box using the IEC C13 mains power cable and press the switch.
3. In each of the chargers, press the “Batt type” button under the battery charger display. “PROGRAM SELECT Lithium Battery” is displayed on the LCD.
4. Press “Start/Enter” button once and use the “Dec” and “Inc” buttons to move across the program types until “FAST CHARGE” appears.
5. Press the “Start/Enter” button and use the “Dec” and “Inc” buttons to move across the battery types until “LiPo” (Lithium Polymer) appears.
6. Press the “Start/Enter” button and use the “Dec” and “Inc” buttons to move across the current value until “15 A” is selected.
7. Press the “Start/Enter” button and use the “Dec” and “Inc” buttons to move across the voltage value until “16.8 V (4S)” is selected.
8. Press the “Start/Enter” button.
9. Press and hold the “Start/Enter” button until the charging starts.

When the batteries are fully charged, the battery charger emits an audible beep and displays the message ‘DONE’. This occurs when the charging current decreases to 3 A (one-fifth of the nominal 15 A charging current). Push on the “Stop” button to interrupt the charging if required.

The complete user manual of the battery charger is available at the link below:

https://www.icharger.pl/manuals/208B_en.pdf

5.5. Checking Battery Status

Once the batteries are charged and the Aquarius disconnected from the charger, the battery status can be checked through the **Status** tab of the Aquarius webpage. The webpage is

Aquarius Ocean Bottom System

accessible when the Aquarius is connected to the deck unit through the Ethernet cable (more details in Section **Error! Reference source not found.**).

Status Network Setup Trigger Data Stream Data Record Storage Logout Help					
System type: Aquarius Host label: NOC#08 Host name: AQU-D66D (192.168.1.162) Serial number: 0D66D					
System Status					
General Status					
Host name	AQU-D66D	Host label	NOC#08	System type	Aquarius
Serial number	0D66D	Firmware version	2.1-16189	IPv4 address	192.168.1.162 (DHCP)
Digitiser temperature	23.989 °C	Digitiser humidity	25.06%	SEED network and station	DG.0D66D (No site)
System time	10:59:11 AM Tue 27-Jan-2026	Uptime	18h 34m 32s	ETH status	sckt: 11/60 data: 0/6
Power Status					
Source	Battery (Capacity 43%)	Voltage	7.241 V	Current	154 mA
				Load	-1117 mW
GNSS Status					
GNSS connection status	Disconnected	Last timestamp	0000-00-00 00:00:00	 <p>Map preview is not available. Offline.</p>	
Last lock time	Never	GNSS stability	Disconnected		
Latitude	-59.900002	Longitude	96.696999		
Altitude	-12.3	Horizontal dilution of precision	Undefined		
GNSS PPS status	Not Trusted No Pulse	GNSS NMEA stream	Bad input		
GNSS Lock state	No lock	Number of satellites	Used: 0 In view: 0		

If the power source is shown as PoE, switch off PoE at the deck unit to verify battery operation. If the Aquarius powers down when PoE is switched off, ensure that the magnetic plug has been removed.

6. OBS Assembly

6.1. OBS Assembly

6.1.1. Attach Ballast

The Aquarius system (comprising of pressure vessel, buoyancy and ancillaries) sits in/on-top-of twin steel ballast rings. The Aquarius system is lowered (by the lifting frame) down on to new ballast rings.



The easiest way to approach this task is to raise the plates off the ground with suitable blocks first, to ensure the lowered Aquarius system sits down on to the ballast plates directly rather than resting on the ground. This can make aligning the circular ridge on the Aquarius buoyancy with the inner circle of the ballast easier, and reduces the force required by the burn-wire tensioning tool (which would otherwise be required to lift the ballast plates before tensioning occurred).

The ballast plates each have three pairs of opposing slots cut into their perimeters at equal intervals, each with a different slot depth. These allow for three different pre-tension settings for the straps suspending the ballast plates, to account for manufacturing variances in the straps and buoyancy.

Aquarius Ocean Bottom System



It is essential to ensure that the slots are correctly aligned between the two ballast plates before proceeding.

Select an opposing pair of slots in the ballast plates (if in doubt, pick the middle pair) and insert the two strap loops into these slots.



Ensure that the strap loops are located as far into the slots as possible, so they cannot slip out when tension is applied.

Aquarius Ocean Bottom System



Now carefully lower the Aquarius system onto the ballast plates.

As the system is being lowered, observe that the protruding circular rim in the underside of the buoyancy aligns and locates properly into the inner circle of the ballast plates. Therefore, the buoyancy is permitted to sit down fully into the ballast plates.

In addition, ensure that the Aquarius system is rotationally aligned with the chosen slots in the ballast plates, such that the straps will travel vertically from the ballast plate slots to the hooks in the burn-wire arms.



6.1.2. Assemble Burn-Wire System

With the Aquarius system located on ballast plates, ensure that the two strap loops are hooked securely over the burn-wire arms. When brought together, the arms should rest equidistantly from the lifting frame (and the centre of the Aquarius) as shown below.

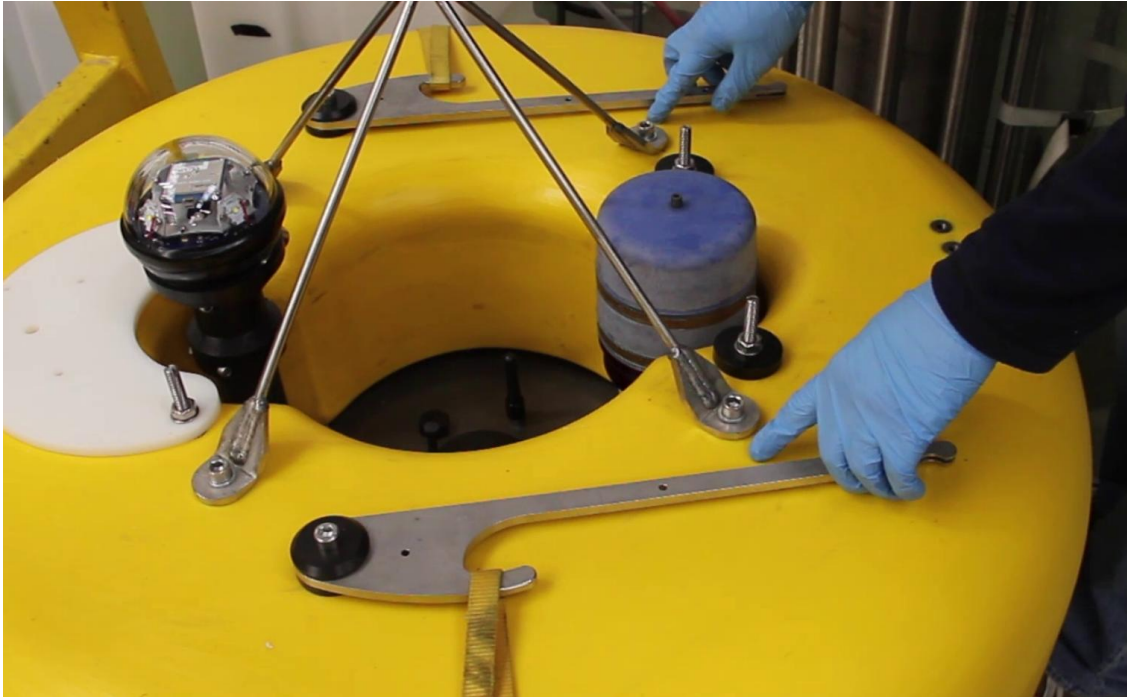

If the arms are not equidistantly spaced, this indicates that either;

- the buoyancy is not properly located into the ballast plates
- the Aquarius is not rotationally aligned with the chosen strap slots on the ballast rings.

In either case, the Aquarius and ballast arrangement must be adjusted.

The arms must be tensioned to permit the burn-wire to be installed. Use the supplied burn-wire tensioning tool to achieve this.

Locate the white wire loop around the smaller/inner notch in one of the arms as shown below:



Note: Some hardware components of the Aquarius may look different than in these photos, however, the burn wire assembly remains the same.

Aquarius Ocean Bottom System

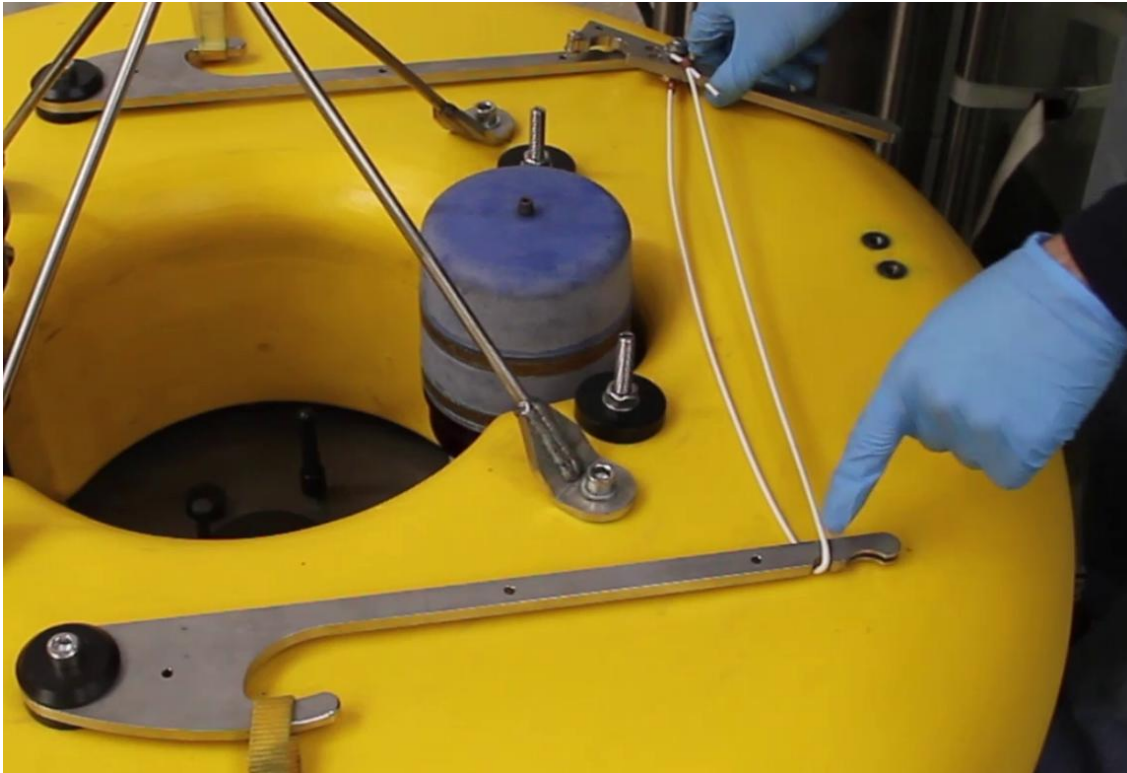

Then align the tip of tensioning tool into the smaller/inner notch in the opposing arm as shown below. Ensure that the retaining washers straddle the arm to prevent the tensioning tool slipping.



Now pivot the tensioning tool around the inner/smaller notch to bring the two arms together. Ensure the wire loop passes around the arm and pivot point.

Aquarius Ocean Bottom System



With the arms tensioned with the tensioning tool, insert each end of a new burn-wire into the larger/outer notch of each of the arms.

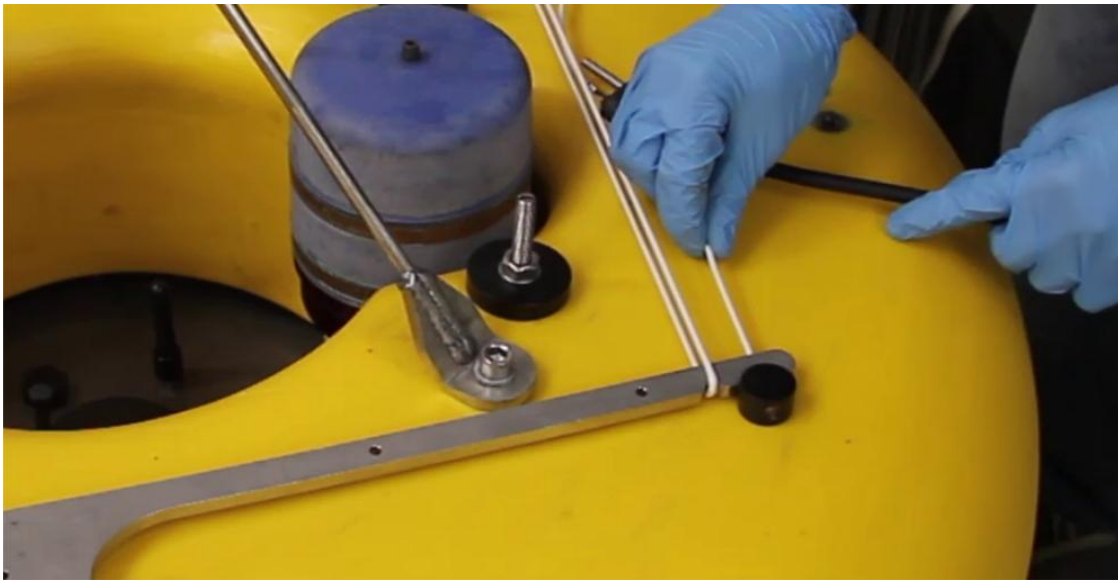

Ensure that the burn-wire itself passes through the slots cut into the arms.

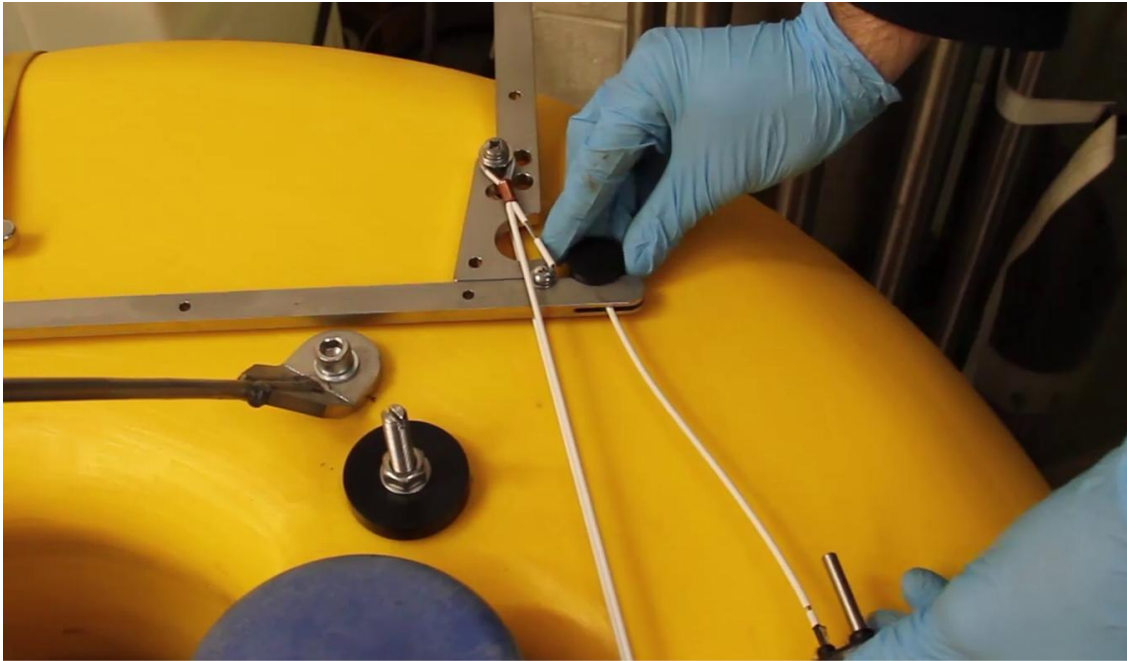

With the burn-wire in place, now release the tensioning tool to transfer the tension of the ballast release system from the tool to the burn-wire itself.

As tension is transferred, ensure that the tensioning tool wire loop passes cleanly around the burn-wire ends and does not force them from the arm notches.

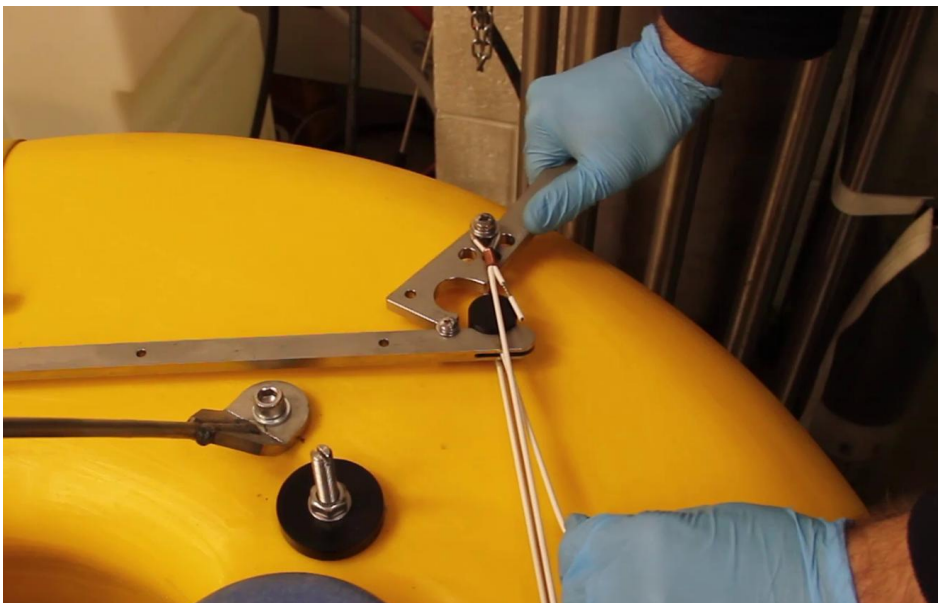

As the tensioning tool is removed, the burn-wire passes completely through the tensioning tool wire loop, including the central potted junction node and electrical cable.

Aquarius Ocean Bottom System

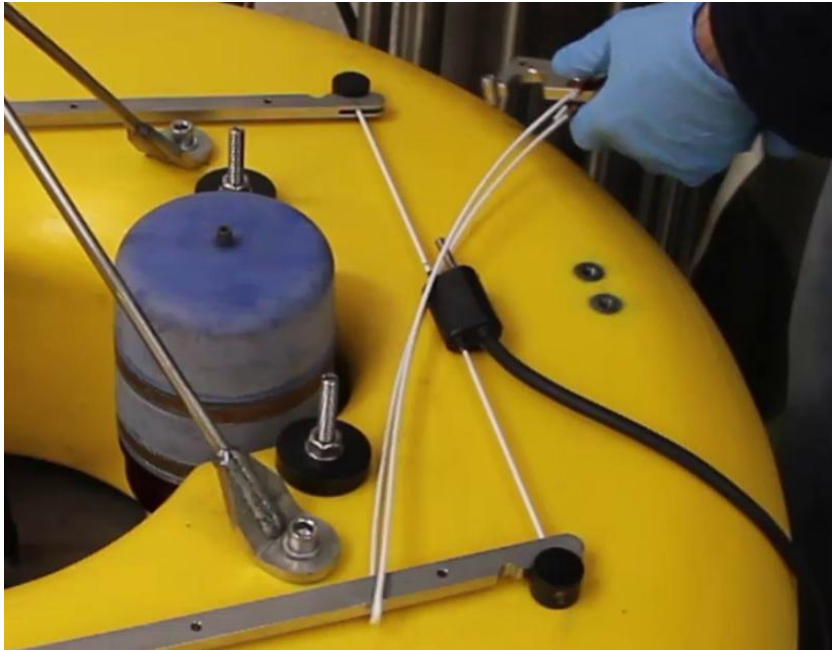

Finally, after cleaning and applying grease as required, the two way Subconn burn-wire connector may be mated with the cable loom. The electrical operation of the burn-wire should be verified by manually activating the burn-wire from Discovery and assessing the anode to cathode voltage with a multimeter (see Section 9.2.5).

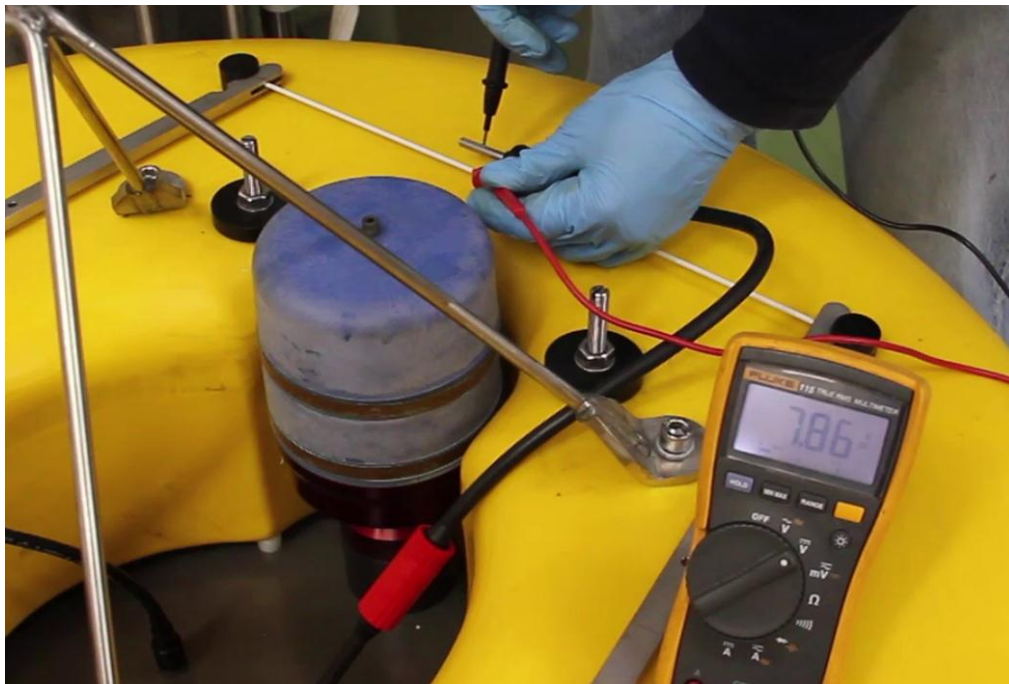

Aquarius Ocean Bottom System



Caution: Before deployment, place the SubConn 13-way connector dummy cap and screw the locking sleeve down. Check also connection of the accessory and Burn-Wire cable by the 8-way SubConn Mini series connector.

Check that all the other caps have been properly screwed down with all the O-rings in place.

7. Deck Unit and Surface Dunker

7.1. Deck Unit Block Diagram

The core of the deck unit is a Single Board Computer (SBC), powered by a large lithium-ion battery pack capable of supporting deck operations for multiple hours to days, depending on usage. The computer has two LAN interfaces. One is dedicated to the Aquarius connection and has a DHCP server available that will provide to the OBS an IP address. A PoE injector allows to provide power to the Aquarius from the deck unit on the same Ethernet port. This will also be used to reboot the LPC in normal power mode, with the LAN interface on. The other LAN interface is dedicated to connections to the external world.

A PTP server is installed inside the deck unit for time synchronization of the Aquarius prior to deployments.

The SBC is also connected to the ULPD and LPC serial consoles and drives the surface acoustic dunker using other two RS-232 connections, one for the Command line of the modem, one for the Data line of the modem.

The deck unit is waterproof and having a large battery pack allows to work on deck, also in rough conditions, without the use of any mains, increasing the safety of the operators.

7.2. Side Connectors Panel

The deck unit right panel contains all the connectors arranged as below



Starting from left, the connectors functions are

- **Power in:** input voltage 90-305 V AC, 43-63 Hz.
- **GPS Antenna:** connect RF cable to the PTP server's GNSS receiver.
- **Dunker:** connect cable to the two serials of the acoustic Dunker, when used.
- **Aquarius Ethernet:** Ethernet cable to Aquarius. PoE can be turned on and off only on this port.
- **Aquarius RS-232:** serial connections to the Aquarius ULPD and LPC consoles.
- **Ethernet:** connection to external LAN.

7.3. Connect to the ULPD and LPC Consoles

The serial consoles of the ULPD and LPC can be accessed using the deck unit terminal. First, use the provided cable to connect the Aquarius the *Aquarius Ethernet* and *Aquarius RS-232* connectors on the deck unit's side panel. Then, open a terminal.

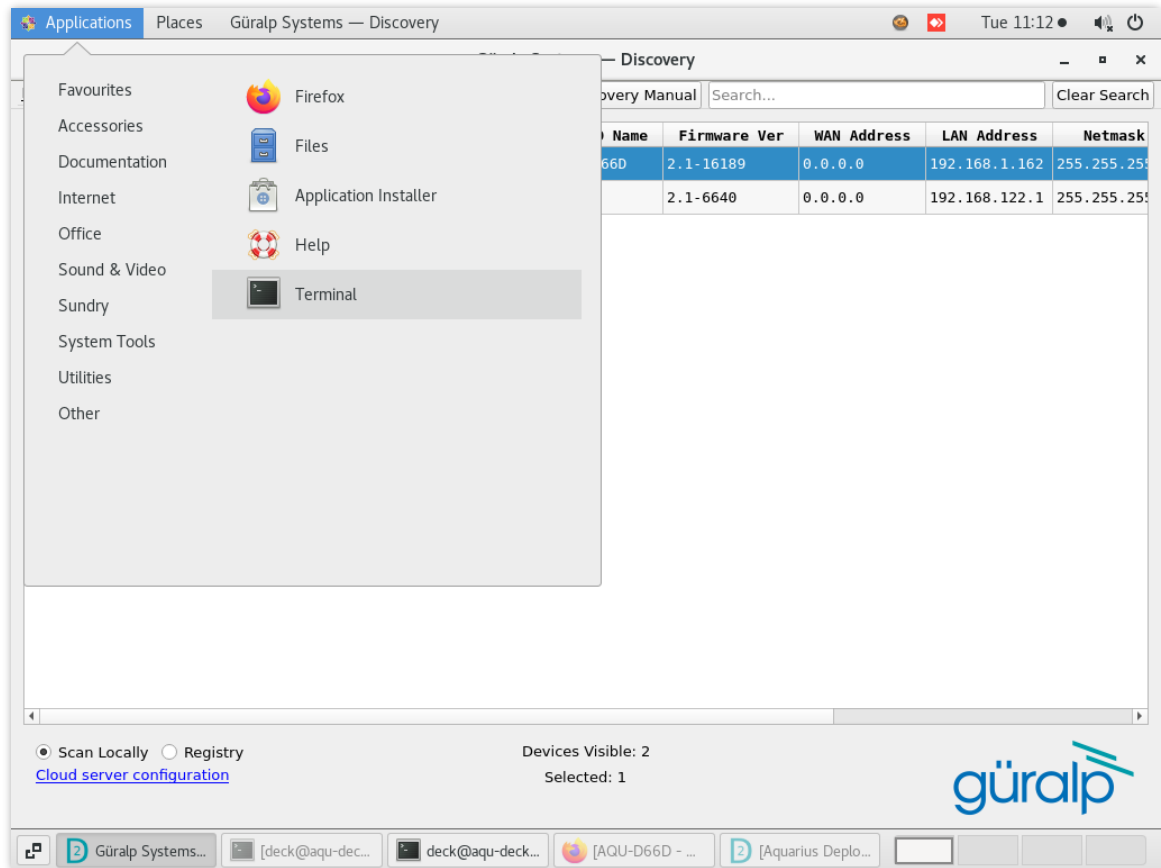

In the terminal, type:

```
./ulpd_console.sh
```

Or

```
./lpc_console.sh
```

To access the ULPD and the LPC consoles, respectively.

8. Configuration via Webpage

8.1. Connect to Aquarius via Discovery Software



Note: For full, general instructions on using the Discovery software (e.g. waveform visualisation, analysis tools, etc.), refer to the Discovery manual: [MAN-DIS-0001](#).

The following sections describe only the Discovery features specific to configuration and control of the Aquarius OBS.

Connect the Aquarius to the *Aquarius Ethernet* connector of the deck unit side panel. Switch on the PoE to provide power to the Aquarius from the deck unit through the same Ethernet port.

The Discovery software is preinstalled on the deck unit computer. One of the deck unit's LAN interfaces operates as a DHCP server, allowing both the LPC inside the Aquarius and the deck unit's single-board computer to automatically obtain their network configuration. The IP address assigned to the Aquarius is displayed in the Discovery main window under the "LAN Address" column. The Aquarius is identified with System type "Aquarius" and Name "AQU-XXXXXX".

Discovery offers access to the Aquarius web interface for configuration and control of the instrument. To open the web page, in Discovery's main window, select an instrument, right-click on it and select "View Web Page" or "View Web Page (in system browser)".

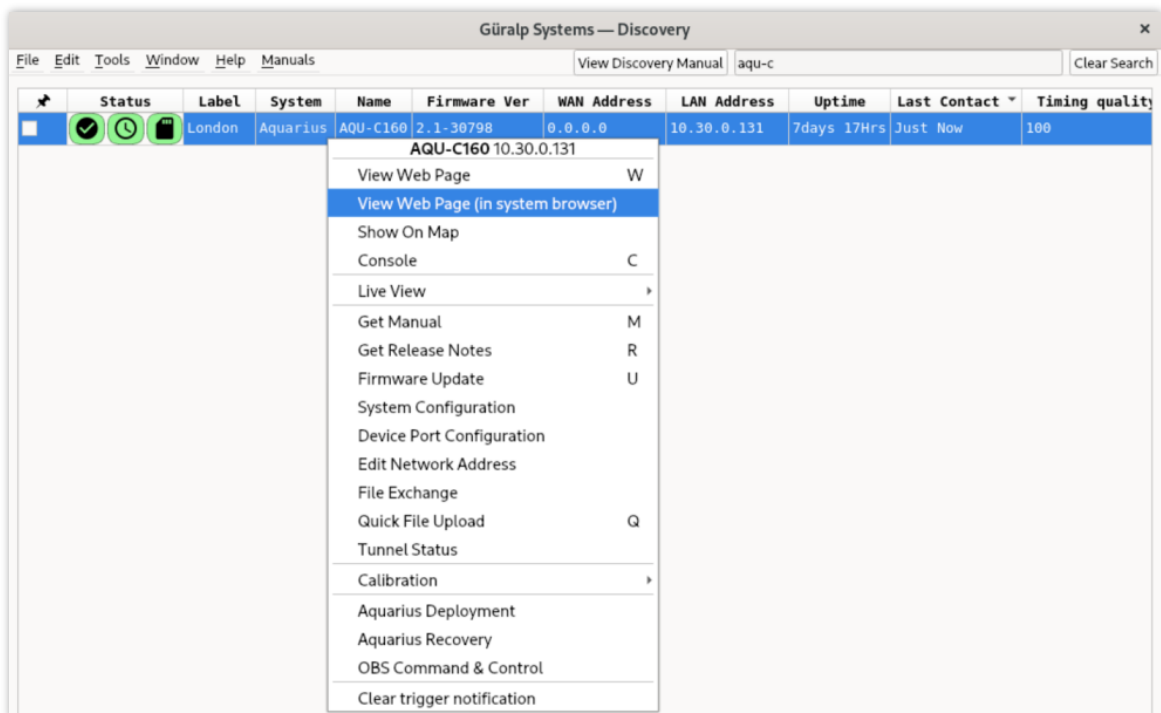

8.2. Web Interface Overview

The Aquarius web interface is organised into several tabs, each providing access to settings and functions. If all the tabs listed below are not present, click the **Login** tab at the top right of the page. This will open the login page.



The Aquarius web interface provides two levels of access: administrator and user. Each level has default credentials as follows:

Access Level	Username	Password	Description
Administrator	admin	admin	Full access to all configuration settings, including network, setup, and sensor parameters.
User	user	user	Limited access to core settings. Configuration controls are restricted.



Note: If the options described in this manual are not visible when logged in with user credentials, log out and log back in using **administrator** credentials.

The list below gives a brief overview of the purpose of each page:

1. **Status:** Displays the current operational state of the device, including sensor timing source status, SD card state, running firmware version, battery charge state. Use this page to monitor the overall health of your Aquarius.
2. **Network:** Provides configuration options for basic and advanced networking features, timing source options, acoustic modem configuration.
3. **Setup:** Allows configuration of SEED naming conventions, low battery voltage thresholds, enter/exit deployment mode.
4. **Trigger:** Enables setup of triggers.
5. **Data Stream:** Provides options to configure channels for streaming.

6. **Data Record**: Provides options to configure channels that will be recorded to the onboard SD cards.
7. **Storage**: Provides access to recorded miniSEED data, as well as SD cards state of health information, metadata and logs.



Note: The following sections do not describe all available webpage options; they focus only on the parameters that are critical to configure or verify before deploying an Aquarius.

8.3. Station Metadata Setup

In this section we focus on SEED (Standard for the Exchange of Earthquake Data) names and how to configure them for your Aquarius pool.

To configure your network and station names, login as either user or administrator and navigate to the **Setup** tab. Under the heading “Digitiser Config” you will find several fields that define your station’s identity and how it is represented both in the interface and in SEED-formatted data. Some fields are used for SEED naming, while others are for display purposes in the web interface and Discovery.

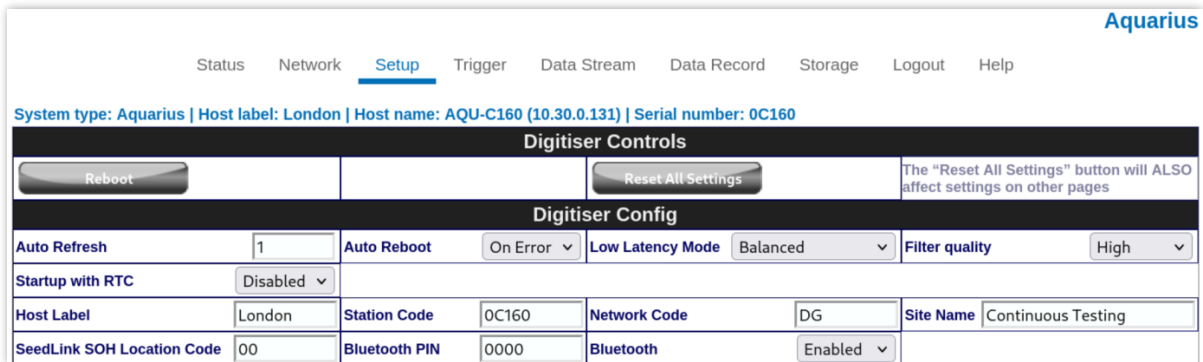

Field	Description	SEED-related
Host Label	A user-friendly name for the instrument in the web interface and Discovery.	No
Station Code	The station code used to identify this station, forming the second part of a SEED name.	Yes
Network Code	A two-character identifier for the network this station belongs to, forming the first part of a SEED name.	Yes
Site Name	A descriptive name for the station location.	No

SeedLink SOH Location Code	The SEED location code used for text-based status messages in SeedLink.	Yes
----------------------------	---	-----

8.4. PTP Settings

The IEEE 1588 Precision Time Protocol is used to synchronise clocks across a computer network. It is significantly more accurate than NTP but generally requires specialised hardware support.

The Aquarius system supports timing provided through PTP when LAN is switched on. A PTP server is installed inside the deck unit for time synchronization of the Aquarius prior to deployments.



Note: The GNSS receiver must be connected to the deck unit via the side-panel connector for the PTP server to acquire time and the Aquarius to get a lock.



UNDERSTAND
OPTIMISE
PROTECT

Aquarius

Status Network Setup Power Trigger Data Stream Data Record Transforms Storage Logout Help

System type: Aquarius | Host label: DIAS-AQUARIUS | Host name: AQU-00205A (10.30.0.73) | Serial number: 00205A

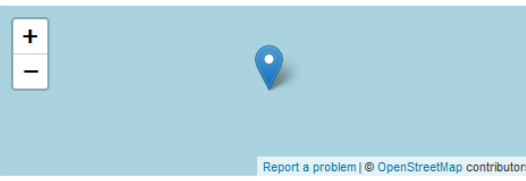
System Status							
General information							
Host name	AQU-00205A	Host label	DIAS-AQUARIUS	System type	Aquarius	Product type	Aquarius
Serial number	00205A	Firmware version	2.0-5707	IPv4 address	10.30.0.73 (DHCP)	SEED network and station	DG.TEST (No site)
Digitiser temperature	29.212 °C	Digitiser humidity	33.68%	Input voltage	2.510 V	Power over Ethernet voltage	0.000 V
Uptime	3h 30m 47s						
GNSS Status							
GNSS connection status	Disconnected	Last timestamp	0000-00-00 00:00:00	 <p>Report a problem © OpenStreetMap contributors</p>			
Last lock time	Never	GNSS stability	Disconnected				
Latitude	-59.899	Longitude	90.1957				
Altitude	-12.34	Horizontal dilution of precision	Undefined				
GNSS PPS status	Not Trusted No Pulse	GNSS NMEA stream	Bad input				
GNSS Lock state	No lock	Number of satellites	Used: 0 In view: 0				
PTP Status							
PTP state	Phase Locked	Last PTP timestamp	2019-09-11 11:04:18Z	Last PTP lock time	2019-09-11 11:02:30Z	PTP stability	99%
Master IPv4 address	10.30.255.35	Master clock class	PRI_REF_PTP	Master clock accuracy	< 100ns (0x21)	Master time source	GPS
Network path delay	32.7 us	Network jitter estimate	-	Network outliers	1%		
Data record status							
microSD status	Recording	microSD total	60686336 KIB	microSD used	67928 KIB	microSD free	99%
Sensors							
Number of sensors detected	2						
Sensor0	Serial number (0)	Firmware ver (0)	0.1				
	Integrator Z (0)	Integrator N (0)	0	Integrator E (0)	0		
	Seismometer Z (0)	Seismometer N (0)	3261771	Seismometer E (0)	2680823		
Sensor1	Serial number (1)	Firmware ver (1)	0.1	Temperature (1)	33.57 °C		
	Yaw (1)	Pitch (1)	0.000°	Roll (1)	0.000°		
	Integrator Z (1)	Integrator N (1)	12752	Integrator E (1)	10480		
	Seismometer Z (1)	Seismometer N (1)	-2936	Seismometer E (1)	28171		

Aquarius Ocean Bottom System

A number of reporting parameters are available in the **Status** tab of the Aquarius webpage, including:

- PTP state
- Last PTP time-stamp and last PTP lock date/time
- PTP Stability
- Master clock IP address
- Master time source.
- Network path delay.
- Network jitter estimate
- Network outliers.

To configure PTP settings, visit the **Network** tab in web page.

The screenshot shows the Aquarius web interface with the 'Network' tab selected. The 'Network Timing' section is highlighted with a red box. The 'PTP Mode' dropdown is set to 'Run always - Override GPS'. The 'PTP Offset Correction' field is set to '0 nanoseconds'. The 'PTP Transmission Mode' dropdown is set to 'Multicast'. The 'Registry Address' field is set to '52 34 40 123' and the 'Group ID' field is set to 'obs-dev'.

Under the heading “Network Timing” are four options:

- **Disabled:** PTP is never used (default settings).
- **Run if needed – Offline backup:** PTP is automatically enabled whenever the GNSS signal is lost. It is disabled while GNSS is available. This mode is used to minimise network traffic when GNSS is the primary timing source.
- **Run always – Online backup:** PTP is always running but GNSS is used as the primary timing source. This mode is useful for faster fall-back from GNSS to PTP timing and for validation that PTP is available.
- **Run always – Override GPS:** PTP is always running and takes priority over GNSS. This mode is useful in a system where PTP is the primary timing source, but GNSS may occasionally be connected for validation purposes.

Select the option “Run always – Override GPS” before the deployment of Aquarius OBS.

PTP can be configured in either multicast or unicast mode. Multicast mode is the recommended setting, as it allows the Aquarius to automatically discover a master clock without requiring an IP address to be specified.

If a master clock is not detected, verify on the PTP server webpage that the transmission type is also set to Multicast. The PTP server webpage can be accessed by opening a web browser and entering the PTP server IP address, which is preconfigured as **192.168.1.20**. Default credentials for username and password are **admin** and **tmachine**, respectively.

If the master clock is still not found, switch both the PTP server and the Aquarius settings to Unicast mode. In unicast mode, the PTP server IP address must be explicitly entered in the Aquarius webpage.

8.5. Acoustic Modem Setup

The acoustic modems addresses can be configured from the **Network** tab in the Aquarius webpage.

Acoustic Modem			
Local modem address	5304	Remote modem address	5308
		Power Levels & Gain	Suitable in air
		WARNING: Non-default settings are in effect	
Tunnel (ppp/l2tp settings) - Test			
LNS url		LNS Username	
No check has been performed yet		Update Connection	Start Test
Tunnel (ppp/l2tp settings) - Permanent Connection			
LNS url_ip	gc01.guralp.com	Connection status	Connection has not started yet...
			off

- “Local modem address” is the address of the acoustic modem in the Aquarius.
- “Remote modem address” is the address of the acoustic modem at the surface.



Note: While the drop-down menu “Power Levels & Gain” allows to set the appropriate acoustic modem power levels, Guralp recommends using the **OBS Command & Control** tool (*Acoustic Configuration* tab) to perform this operation, as described in Section 9.1.2.

8.6. Low Battery Voltage Thresholds

The Aquarius can be configured with battery-voltage thresholds to protect both the data and the instrument. When the battery voltage falls below a user-defined **hibernation limit**, the system enters a low-power hibernation state in which recording is stopped to conserve energy.

If the battery voltage continues to decrease and reaches a second, lower **release limit**, the ballast release mechanism is triggered, causing the Aquarius to resurface automatically. This safeguard is intended to prevent the instrument from remaining on the seafloor with

depleted batteries. Early resurfacing increases the likelihood of successful recovery, even if the planned deployment duration cannot be completed.

Power							
1 Source	Battery (Capacity 43%)	1 Voltage	7241 mV	1 Current	155 mA	1 Load	-1127 mW
1 Hibernate Limit	6500 mV	1 Set Hibernate Limit	6500	1 Release Limit	6000 mV	1 Set Release Limit	6000

The battery voltage thresholds (in mV) are configured at the bottom of the **Status** tab of the webpage. Typical values are 6500 mV for the hibernation threshold and 6000 mV for the release threshold.

8.7. Streamed Data Setup

The monitoring and configuration of transmitted data is handled using the **Data Stream** tab of the webpage. Most data streaming channels are only included for testing purposes prior to the deployment.



Note: The channels **1CVDAC** and **1PLL00** must be enabled and set to a sample rate of **5 Hz**, including during deployment. These channels allow the monitoring of the internal clock DAC frequency and PLL clock offset, respectively, which are essential for assessing the status of PTP locking.

If these channels are not visible, ensure that the “Display Streams” drop-down menu (top left) is set to All, and the “Display on Page” drop-down menu (top right) is set to Sensor 1.

The names and contents of each channel are described in Section 11.1.

 **Note:** When changing a setting in the Aquarius webpage, ensure that you wait until the page refreshes before changing another setting. This allows time for the previous change to take effect.

The drop-down box at the top-left of the page named “Display Streams” filters out visible channels among Enabled and Disabled. The option “Apply configuration for tap groups” automatically apply the same configuration to three streams that belong to the same tap, e.g. 1VELZ0, 1VELN0, 1VELE0. The drop-down box at the top-right of the page named “Display On Page” allows to move from different sensors, e.g. Sensor 1.

 **Note:** The most relevant streams for the Aquarius are located on Sensor 1. Other sensor’s streams could be ignored by the end user.

The page is divided in four columns:

- in most-left column, drop-down boxes are available for each channel to either select a sample rate or to exclude the channel from streaming (by selecting the “Disabled”

Aquarius Ocean Bottom System

option). All streaming can be stopped by clicking the **Disable All** button. Default channel configuration can be applied by clicking the **Restore Default** button.

- second column from the left is not relevant for the Aquarius OBS;
- in third column from left, Location and Channel SEED codes can be configured. Cells are greyed out by default (default values applied) and they can be edited by clicking on the check-box;
- in most-right column contains links to the RESP files associated to each of the seismic channels (see Section 10.1.3).

Upon changing the sample rate or changing Location and Channels codes, the Aquarius will need to be restarted for the changes to come into effect; this can be done by pressing the **Reboot** button.

Once the Aquarius has successfully restarted, the full web browser display and controls will be available for use again.

8.8. Recorded Channels Setup

The configuration of recorded channels is handled using the **Data Record** tab of the webpage.



Note: Only the taps with name ending in **FR** (Fix Recording) should be enabled.

The sample rates for FR channels are fixed:

- main seismic channel: **250 Hz**
- mass position, PLL offset, pressure, humidity, internal temperature and input voltage: **5 Hz**
- STA/LTA channels, power and external temperature: **1 Hz**.

The screenshot shows the 'Data Record' configuration page for the Aquarius system. At the top, there is a navigation menu with options: Status, Network, Setup, Power, Trigger, Data Stream, **Data Record**, Transforms, Storage, Logout, and Help. Below the menu, system information is displayed: System type: Aquarius | Host label: DIAS-AQUARIUS | Host name: AQU-00205A (10.30.0.73) | Serial number: 00205A.

The main content area is titled 'Data Record' and contains several control buttons: 'Disable All', 'Restore default', 'Reboot', 'Copy to Data Stream', and 'Copy FR to all'. A 'Recording status' indicator shows 'Recording' in green. There are also checkboxes for 'Apply configuration for tap groups' and 'Display On Page' (set to 'Sensor 1').

The 'Channels configuration' section is a table with columns for Channel sampling rate, Data transform, SEED name, and RESPONSE file. It is divided into several categories:

- Seismic channels:** S1SeisXFR (100 Hz), S1SeisZFR (250 Hz), S1SeisNFR (250 Hz), S1SeisEFR (250 Hz).
- Mass position channels:** S1IntZFR (5 Hz), S1IntNFR (5 Hz), S1IntEFR (5 Hz).
- MEMS accelerometer channels**
- Magnetometer channels**
- Low latency seismic channels**
- Auxiliary channels:** S1PresFR (5 Hz), S1HumidBFR (5 Hz), S1ExtPresFR (5 Hz), S1APGFR (5 Hz), S1STAZFR (1 Hz), S1LTAZFR (1 Hz), S1RatioZFR (1 Hz).

The names and contents of each channel are described in Section 11.2.

 **Note:** When changing a setting in the Aquarius web page, ensure that you wait until the page refreshes before changing another setting. This allows time for the previous change to take effect.

The drop-down box at the top-left of the page named “Display Streams” filters out visible channels among Enabled and Disabled. The option “Apply configuration for tap groups” automatically apply the same configuration to three streams that belong to the same tap, e.g. S1SeisZFR, S1SeisNFR, S1SeisEFR. The drop-down box at the top-right of the page named “Display On Page” allows to move from different sensors, e.g. Sensor 1.

 **Note:** The most relevant streams for the Aquarius are located on Sensor 1. Other sensor’s streams could be ignored by the end user.

The page is divided in four columns:

Aquarius Ocean Bottom System

- in most-left column, drop-down boxes are available for each channel to either enable the recording or to exclude the channel from recording (by selecting the "Disabled" option). Default channel configuration can be applied by clicking the **Restore Default** button.
- second column from the left is not relevant for the Aquarius OBS;
- in third column from left, Location and Channel SEED codes can be configured. Cells are greyed out by default (default values applied) and they can be edited by clicking on the check-box;
- in most-right column contains links to the RESP files associated to each of the seismic channels (see Section 10.1.3).

Upon changing enabling/disabling channels or changing Location and Channels codes, the Aquarius will need to be restarted for the changes to come into effect; this can be done by pressing the **Reboot** button.

Once the Aquarius has successfully restarted, the full web browser display and controls will be available for use again.

8.8.1. MicroSD Cards Monitoring and Maintenance

The microSD card and data recording status can be monitored in the upper panel of the **Storage** tab.

MicroSD cards need to be specifically formatted to operate with the Aquarius. The cards shipped with the Aquarius are supplied pre-formatted.

Data are stored on the microSD cards in miniSEED format. Each channel is saved as a series of 128 MiB files. Instrument and station metadata (e.g. instrument response, coordinates, compression type etc.) are stored in "Dataless SEED" format.

The left-hand column provides details of the primary microSD card and the right-hand column shows the status of the backup card.

SD Cards status			
External microSD card present	PRESENT	Number of 128-MiB miniSEED files	452
External microSD card usable	USABLE	Internal microSD card usable	USABLE
External microSD card init count	1	Internal microSD card init count	1
External microSD card is primary microSD card	PRIMARY	Internal microSD card is primary microSD card	BACKUP
Primary microSD card is recording samples	RECORDING	Backup microSD card is recording samples	RECORDING

Sections of this panel indicate the status of the following:

- Whether a card is inserted;
- Whether an inserted card is usable (i.e. correctly formatted); and
- Whether the card is recording data.

The card re-formatting process fills the card with 128 MiB files containing zeroes. Each file is given a temporary, place-holder name. When data are written, these files are renamed and then over-written with data.

There are two methods for card reformatting: “**Quick format**” and “**Full format**”. The quick format simply moves the write-pointer to the beginning of the recording space, hence overwriting any existing data. The full format, in contrast, erases all the existing data.

 **Note:** A full card format can take several hours and is therefore not recommended on board prior to deployment. The *Aquarius Deployment* tool guides the user through a deployment checklist that includes a **Format Cards** button, which only performs a quick format (more details in Section 9.2.4).

The formatting process formats both fixed and removable cards, sequentially. A series of tests separated only by quick formats can leave some files with residual data in them. This is not normally a problem because a deployment will typically create data-sets longer than any test, over-writing any data remaining from the tests.

To quick-format the cards, click the **Quickformat Cards** button in the **Storage** tab: a dialogue box will appear to confirm the formatting operation – click on OK button to continue. The instrument web page will refresh and return to the **Status** tab. The reformatting operation is now complete.

To full-format the cards, click the **Fullformat Cards** button in the “Storage” tab and a dialogue box will appear to confirm the formatting operation – click on OK button to continue. The process takes several hours: check the status countdown indicators on the top-right of **Storage** tab.



The screenshot shows the 'SD Card control' interface. It contains three buttons: 'Unmount Cards', 'Quickformat Cards', and 'Fullformat Cards'. To the right, there is a 'Formatting progress:' indicator showing 0% completion and a text label '-196 minutes remaining'.

 **Note:** If the card recording status is shown as **NOT RECORDING**, first try **Quickformat Cards**. If this does not resolve the issue, **Fullformat Cards** may be used. This is the **only situation in which a full format is recommended**.

8.9. Configuration Download

A configuration Import/Export tool can be access through Discovery's main window by right-clicking on the Aquarius entry and selecting **System Configuration**. Configuration files can be exported for archiving and to replicate the complete system configuration on one or more other systems.

The config file is in text readable format. It comprises name/value pairs. The names are the same as they appear on the instrument's webpage (see Section **Error! Reference source not found**). Pull-down menus appear as enumerations (index into the list).

Configuration files can be manually edited if required, and individual items may be removed. Any parameters omitted from a configuration file will remain unchanged when the file is applied. This is useful, for example, when updating channel sample rates across

multiple instruments without modifying other settings, or when creating a configuration file containing a single parameter to apply that change to a group of systems.

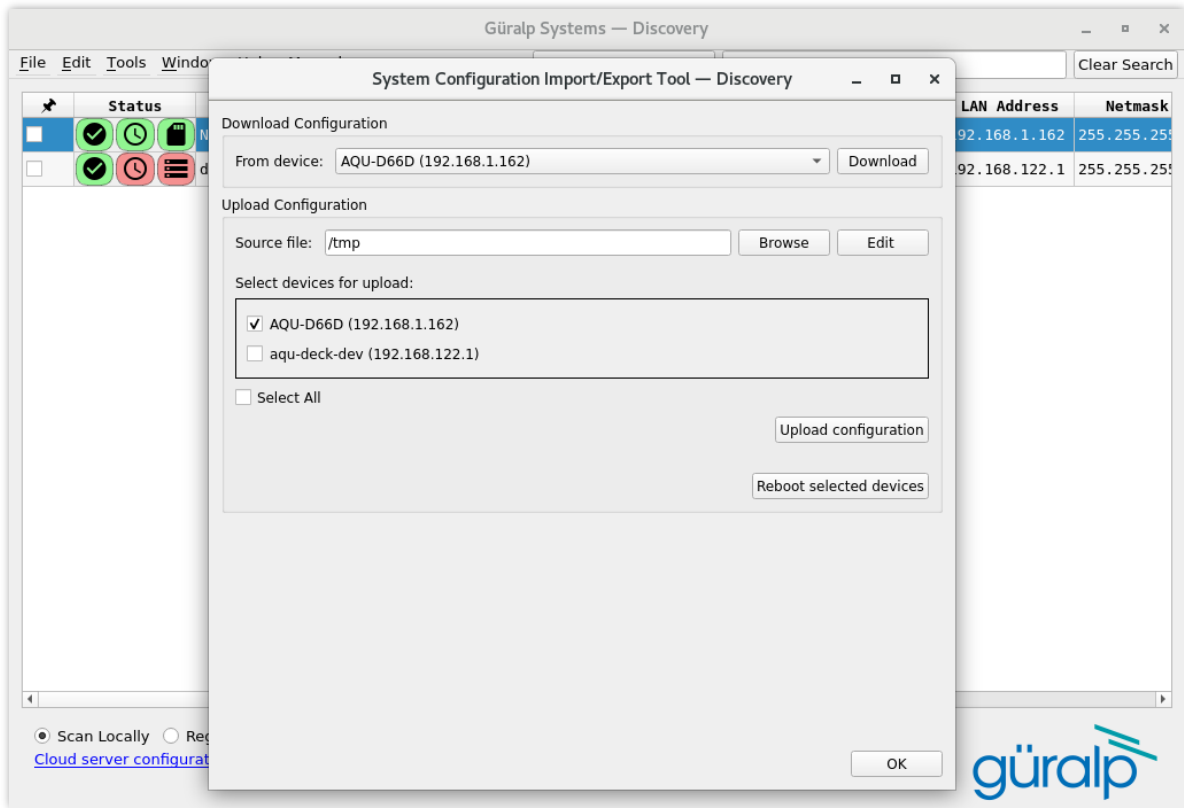

Click on the **Download Configuration** button to export the configuration from the device specified in the Configuration Source section. Use the **Upload Configuration** button to upload an existing to the device(s) ticked in the Devices section. After a configuration file is uploaded, the device must be rebooted for the changes to take place. You can do this by clicking the **Reboot Selected** button.

8.10. Deploy Mode

Although the **Setup** tab of the webpage includes an option to deploy the Aquarius, Güralp recommends following the deployment procedure in the *Aquarius Deployment* tool in Discovery, as described in Section 8.10.

8.11. Stop Recording and Undeploy

After recovery, connect the OBS to the deck unit using the Ethernet cable and enable PoE on the deck unit. This supplies power to the OBS from the deck unit rather than the internal batteries, and causes the LPC to reboot in normal operating mode with the LAN interface enabled. The web interface becomes available again.



Caution: Before using the webpage after recovery, it is essential to follow the steps in the *Aquarius Recovery* tool in Discovery, as described in Section 9.4. These include:

- Waiting until the PTP stability reaches 100%
- Performing a flush to SD cards
- Taking a note of the time offset
- Performing a first system reset

Time offset information is not stored on the microSD cards and will be lost once the system is reset.

After the steps in the *Aquarius Recovery* tool in Discovery have been executed and the time offset written down, the Setup tab of the webpage can be used to put the Aquarius in its **Deployed without Recording** state (described in Section 4.2). This can be done by pressing the **Stop Recording** button.

Subsequently, click on the **Undeploy** button and then on the **System Reset** button to bring the Aquarius back to its **Undeployed** state.



Note: Performing a system reset from the *Aquarius Recovery* tool alone is not sufficient to fully undeploy the Aquarius. To return the system to the **Undeployed** state, a second system reset must be performed from the webpage.

If the second reset is not performed, the Aquarius will revert to the **Deployed** state after a short period of time. This is a deliberate safeguard to prevent accidental undeployment.

9. Discovery Tools

Right-clicking on the Aquarius row in Discovery allows to access various functionalities, including OBS specific widgets, such as the "*Aquarius Deployment*", the "*Aquarius Recovery*" and the "*OBS Command & Control*".

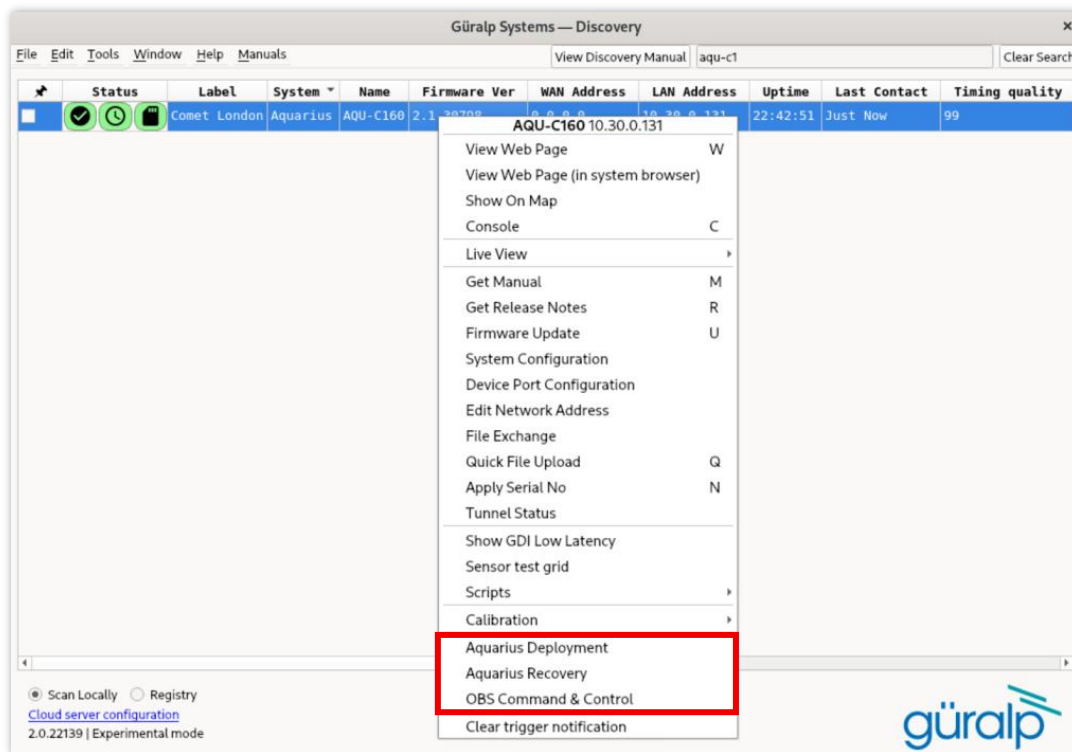

Note: When the Aquarius is deployed (that is, with the LAN disabled and no longer visible in Discovery), the tools can still be accessed via **Tools** → **OBS**. This allows the user to communicate acoustically with the Aquarius and to access the *OBS Command & Control* tool when ballast release is required.

Aquarius Ocean Bottom System

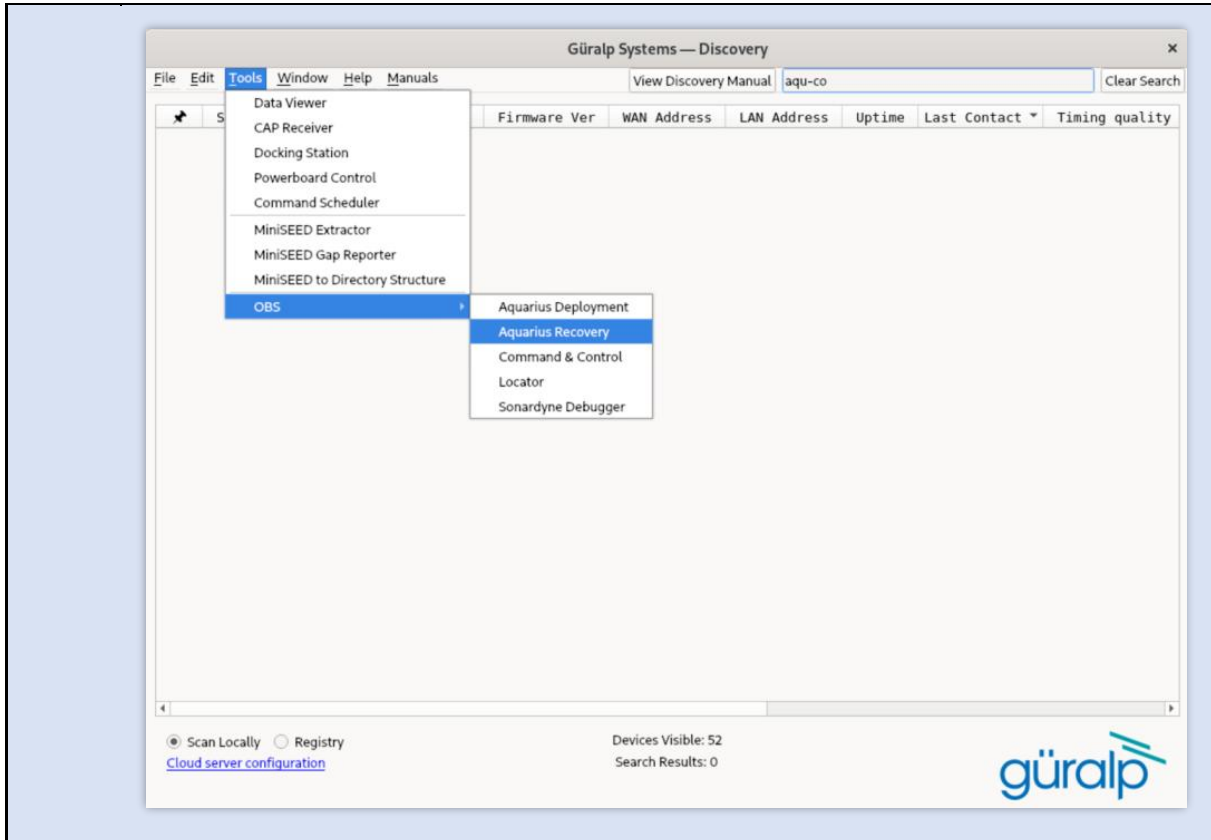

9.1. OBS Command & Control

This Discovery **OBS Command & Control** widget offers the end user a quicker way to go through the final steps of a pre-deployment procedure and allows to manage all the functionalities available through the acoustic communication, including the data retrieval and the ballast release.

Aquarius Ocean Bottom System

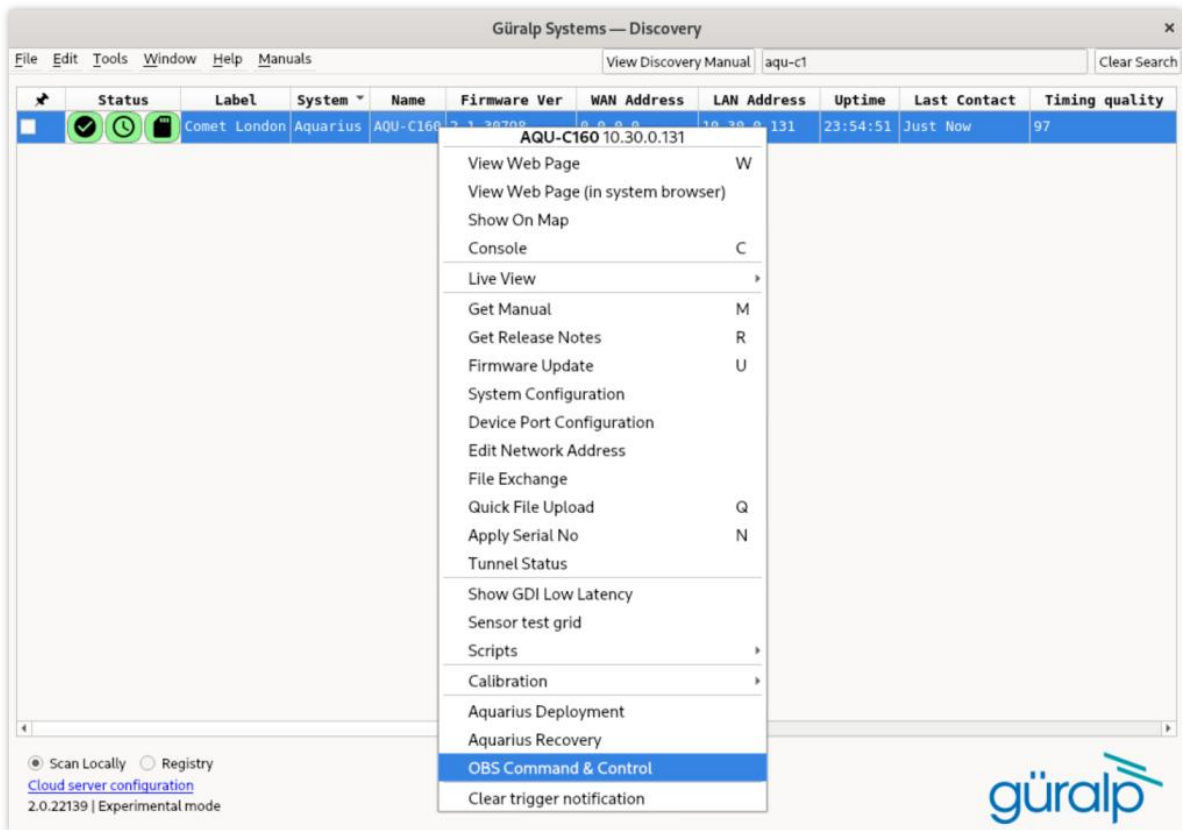

The bar at the top of **OBS Command & Control** configures the acoustic modem. The first address is the device which hosts the acoustic modem. In most cases this will be the local machine.



The second address is the one of the acoustic modem in the Aquarius. This address can be found in the Aquarius webpage as “Local modem address” (see Section 8.5).

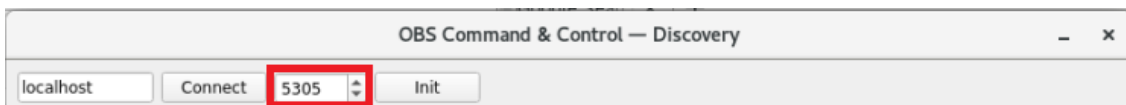

Click on **Connect** button to initiate the connection with the remote or local surface dunker driver. After this, press the **Init** button. Wait for the status at the bottom-left of the window to be **Ready**. Only after these steps the end user can send commands through the surface acoustic dunker.





9.1.1. State of Health of the Acoustic Link

Aquarius Ocean Bottom System

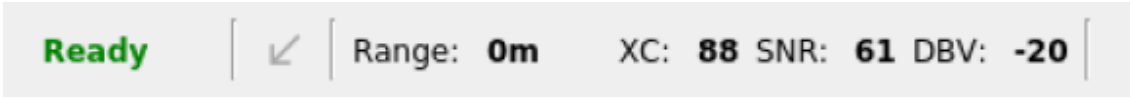
The **OBS Command & Control** shows the status of the acoustic link at the bottom window and it updates it every time an exchange of information with the modem occurs.



- **Status:** is the status of the acoustic communication and it can be **Ready**, **Busy**, **Not Ready** or **Network Error**.
- **Arrow:** indicates the direction of the communication ( bottom → surface or  surface → bottom).
- **Range:** is the slant range and it is calculated from the Turn-Around-Time.
- **XC:** Cross Correlation
- **SNR:** Signal to Noise Ratio
- **DBV:** Degree of Voice Breaks.

 **Note:** In certain situations (i.e. surface modem power-cycles during acoustic activity), the status of the acoustic communication could get stuck in **Busy**. Clicking on the **Init** button should bring the status back to **Ready**.

9.1.2. Acoustic Configuration

The *Acoustic Configuration* tab of **OBS Command & Control** widget allows the user to configure acoustic modems at both ends of the acoustic link. Configuration of the local (surface, acoustic dunker) modem is performed via physical connection. Configuration of the remote (ocean bottom, deployed Aquarius) modem is performed over the acoustic link itself.

Depth Configuration

Use the drop-down menu to select the depth range at which the OBS is deployed. Click on **Local [Dunker]** → **Set & Save** to configure the acoustic modem attached to the deck-unit (dunker) or buoy unit via serial connection; click on **Remote [Aquarius]** → **Override** to configure the acoustic modem inside the Aquarius via acoustic link.

Aquarius Ocean Bottom System

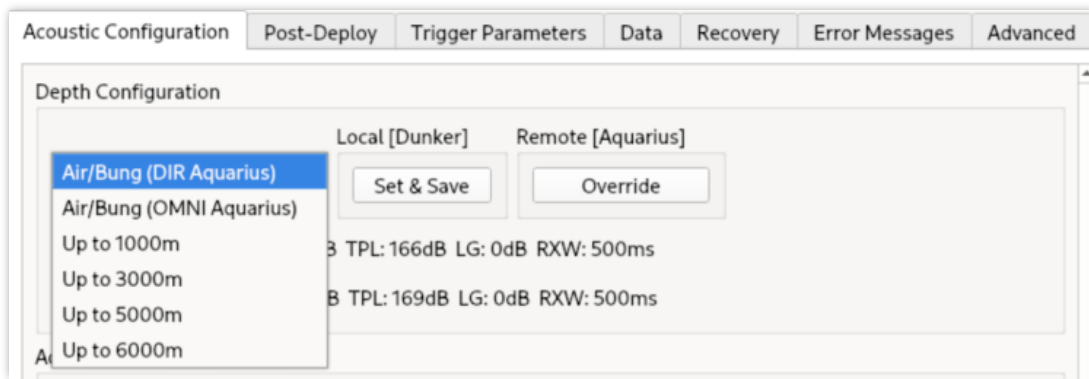

Acoustic Baud Rate

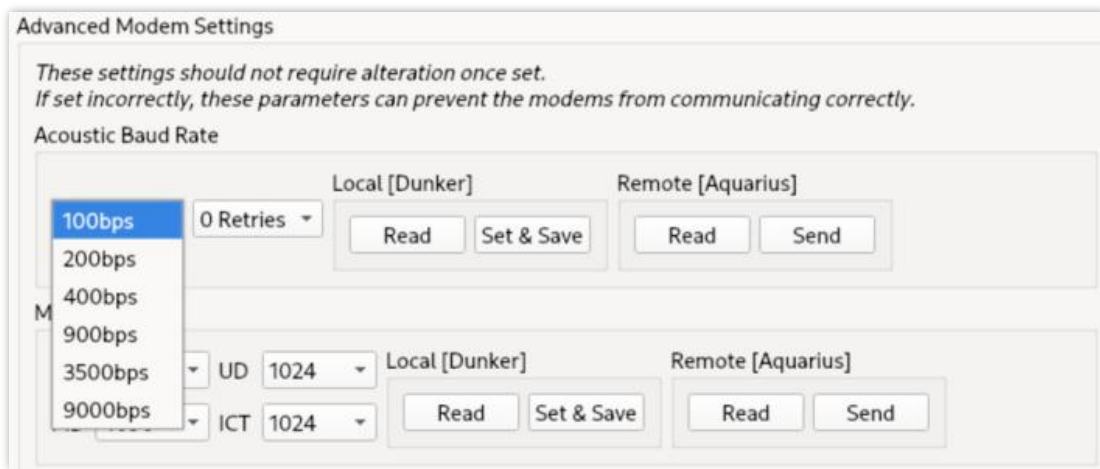

Use the drop-down menu to configure the acoustic modem transmission speed (baud rate). **Local [Dunker]** buttons are for the acoustic modem connected to the deck-unit, **Remote [Aquarius]** ones for the acoustic modem in the Aquarius. The default of 100bps should be suitable in most cases.

The drop-down menu in the *Acoustic Baud Rate* section is used to set the “Master Retries (MR)” parameter. This parameter specifies the maximum number of times the master modem will request retransmission of data that was received with errors. Data is transmitted in Sub Frames. If a Sub Frame is received correctly, it is retained; only Sub Frames received with errors are requested again. Once all Sub Frames have been received without errors, they are automatically reassembled into the complete data message.

In challenging acoustic environments, this retransmission mechanism significantly improves data reliability. However, increasing the MR value may introduce additional latency before the data is delivered to the communication port.

Aquarius Ocean Bottom System

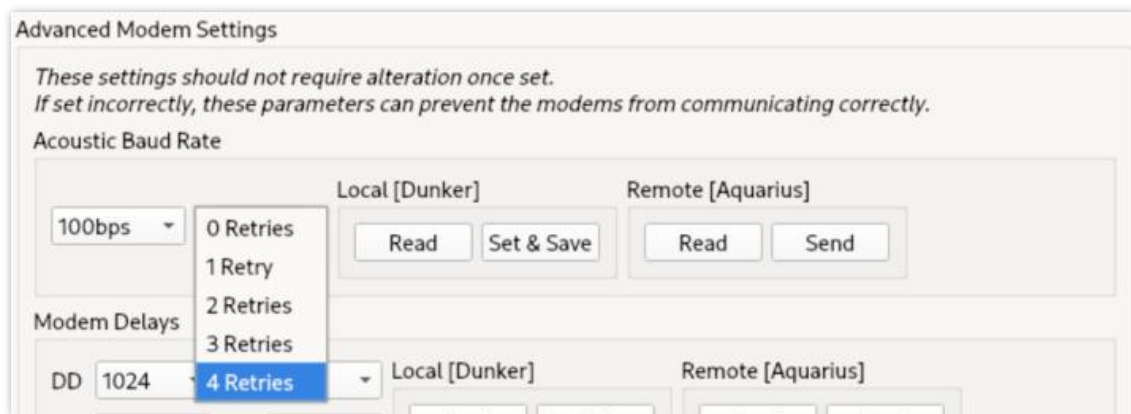

The “Modem Delays” parameters in the *Acoustic Configuration* tab are set at the factory and none of them should require alteration. In case of necessity, only an experienced user with guidance from Güralp should modify them. A detailed description of these parameters can be found in Section 13.1.1.

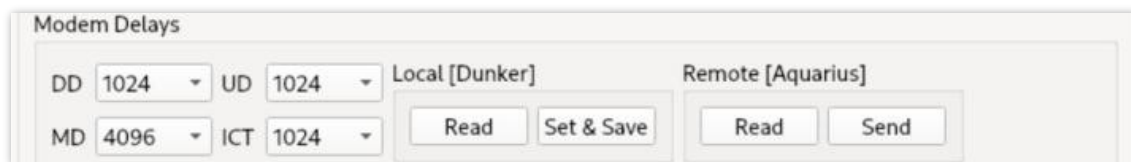

9.1.3. Post Deployment

The *Post-Deploy* tab of **OBS Command & Control** provides an interface for general configuration, control and status observation of an Aquarius via acoustic modem.

All operations in this widget require the acoustic modems to have been configured correctly.

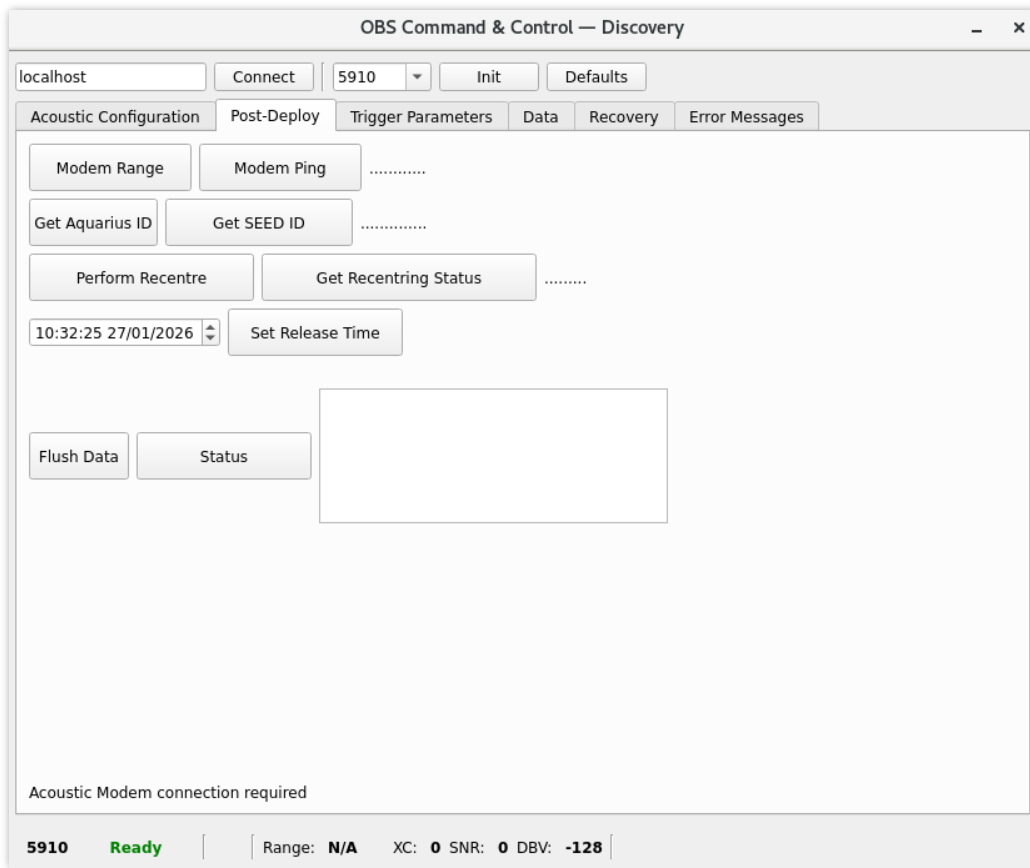

Modem Range and Modem Ping

Two methods of making initial acoustic contact with a deployed Aquarius are available.

The **Modem Range** button is used to measure an individual range to a remote instrument. This is the shortest message that could be sent to the bottom modem, useful for diagnosing acoustic communication issues in challenging scenarios for the acoustic link, as explained in Section 13.3.1

In the presence of a good acoustic link, **Modem Ping** may be used to verify the connection with the acoustic modem. The last ping in "uS" will be printed. This is the Turn-Around-Time reported by the acoustic modem.

 **Note:** The Turn-Around-Time (TAT) is the time in milliseconds that the remote instrument takes to respond to an interrogation signal, starting from when the interrogation is sent until the acknowledgement is received.

Get Aquarius ID and SEED ID

Further verification of the acoustic link with an Aquarius is available through the **Get Aquarius ID** and **Get SEED ID** buttons. These interrogate the LPC (if awake) for the respective IDs, which will be displayed if received.

Aquarius Ocean Bottom System

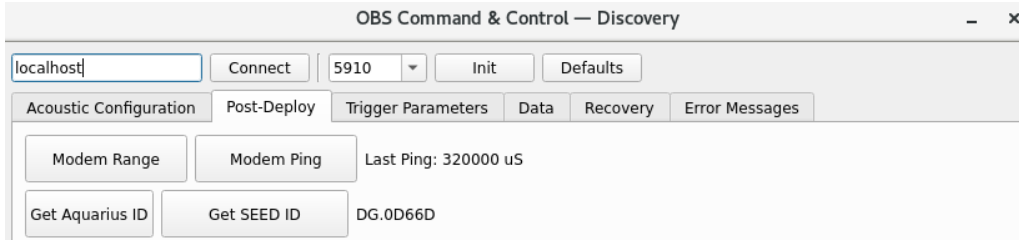

Recentring

Click on **Perform Recentre** to start the centring of the main sensor's components. When centring is ongoing the status is "Centring".



The centring happens in 2 stages: mechanical and electrical. The first, i.e. mechanical, stage takes only a few seconds if the sensor is not moving. The second, i.e. electrical, stage takes around 10 minutes.

You can monitor the status of each centring state by clicking on **Get Recentring Status**.

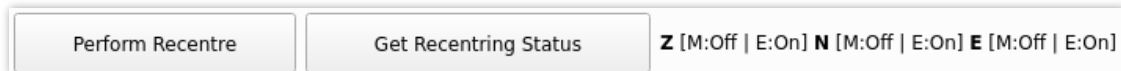

Z, **N** and **E** are the three components, Vertical, N/S and E/W respectively. **M** indicates the status of the mechanical centring, **E** the status of the electrical centring.

- M:On | E: On = this status indicates that both mechanical and electrical centring stages are in progress
- M:Off | E: On = the mechanical stage is over, while the electrical centring is still in progress
- M: Off | E: Off = both mechanical and electrical stages are over and the sensor is centred.

Flush Data to the LPC

Click on **Flush Data** to flush data from the ULPD memory to the LPC microSD card. This operation is needed when the end user needs to retrieve last minutes data acoustically. After a flush is performed, the data can be downloaded through the Data tab of the widget (see Section 9.1.5).

Set Timed Burn-Wire

In the *Post-Deploy* tab of **OBS Command & Control**, it is possible to update the Burn-Wire timer in the ULPD via acoustic commands. Select the date and time at which the Burn-Wire should be released. Once the time is configured, click on **Set Release Time** to send the command to the OBS via acoustic. If the command is sent correctly the status notifies with the message "Taken".

Aquarius Ocean Bottom System

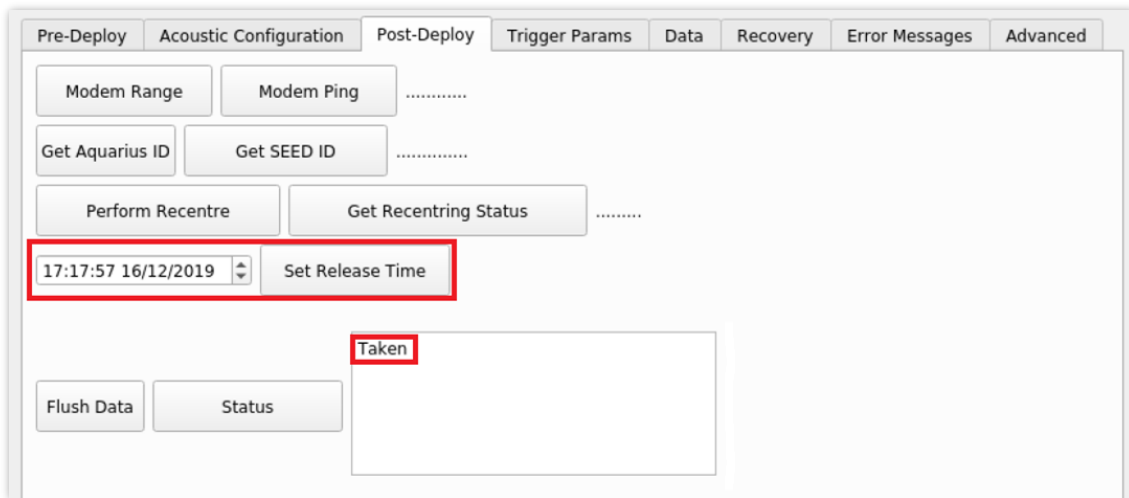

Get Aquarius Status

Clicking the **Status** button requests the current state of the Aquarius and displays it in the output box. The returned information includes the timestamp of the status request, release time status, inferred depth (from pressure), battery voltage and remaining charge, power consumption, and MEMS accelerometer and magnetometer readings.

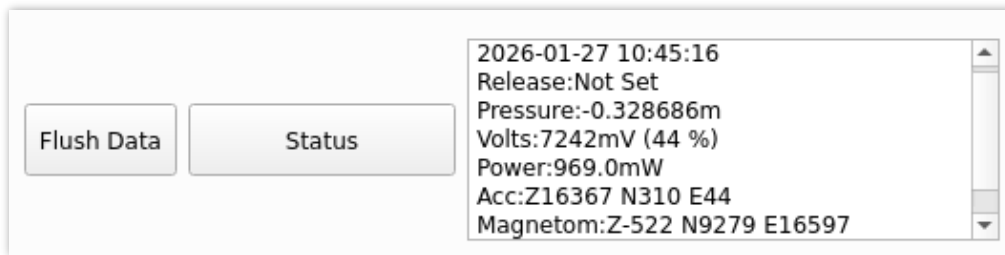

The **Status** button can be used at multiple stages of deployment and recovery. For example, it can be used to check battery status before deployment, monitor increasing pressure as the Aquarius descends, verify MEMS sensor outputs once the instrument is on the seabed to confirm it is approximately level, and track decreasing pressure as the Aquarius resurfaces during recovery.

9.1.4. Trigger Parameters

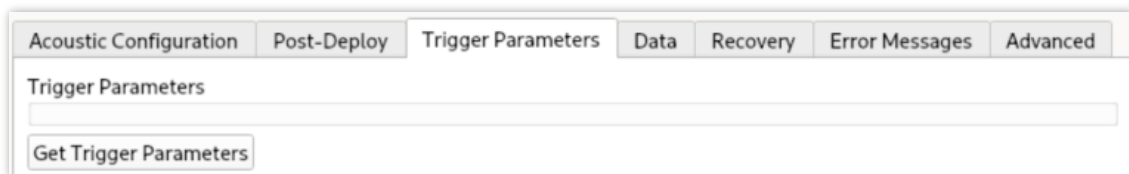

9.1.5. Data

The *Data* tab of *OBS Command & Control* provides an interface for downloading data after a flush to the LPC has been performed. Right-click on the **Populate** button to select which

Aquarius Ocean Bottom System

channel categories to download (for example, *Taps with Events*, *Seismic Taps*, or *Other Taps*). The available channels are then displayed in the panel below.

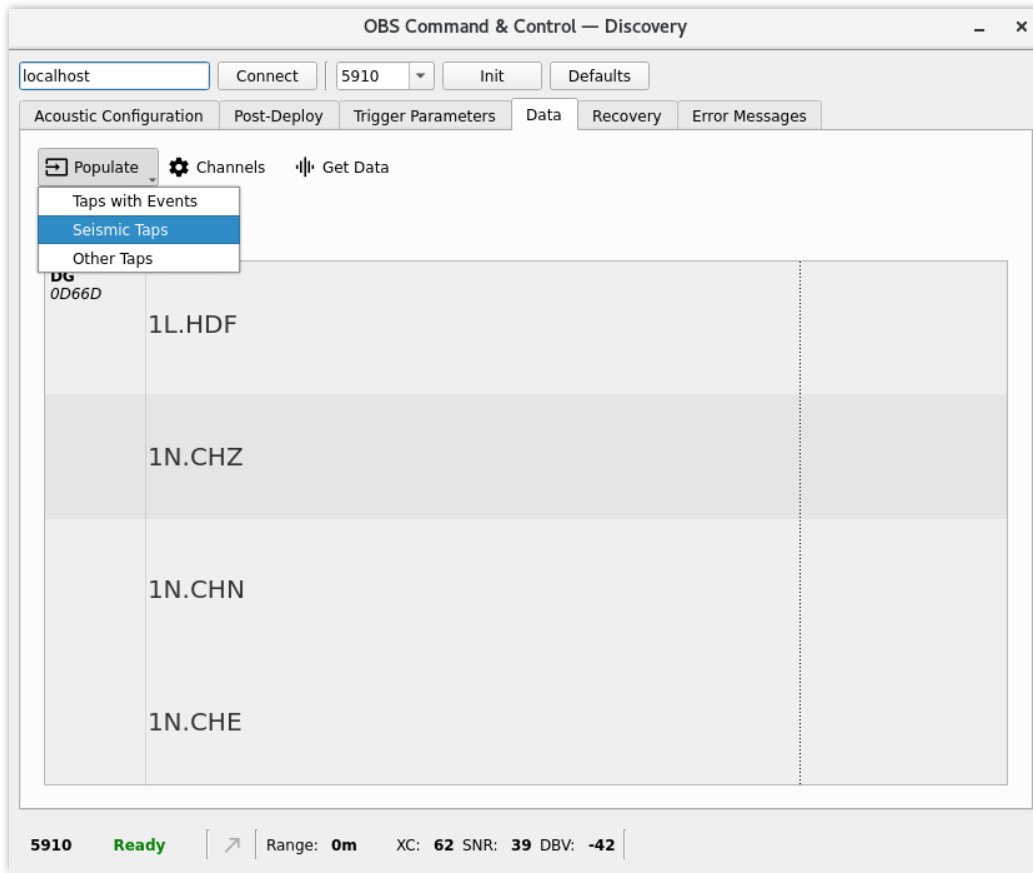

Select the channels to be downloaded by clicking the **Channels** button. Then click **Get Data** to open the *Request OBS Data* window, where data can be downloaded for a specified time range.

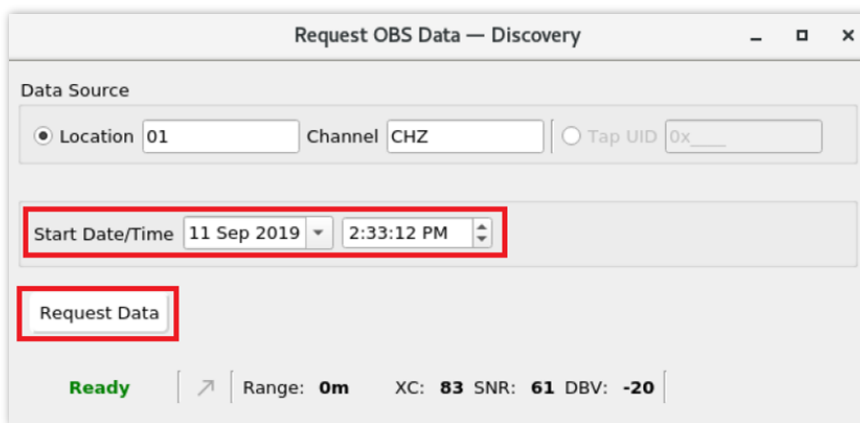

9.1.6. Recovery (Ballast Release)

The *Recovery* tab of *OBS Command & Control* allows the user to recover a deployed Aquarius via the acoustic link.

Aquarius Ocean Bottom System

To activate the Burn Wire and begin a recovery:

- Click on the **Get the remote modem's unique ID** button to obtain the seabed modem hard-coded address.
- Set the amount of time for the Burn Wire activation.

Note: 900 seconds is usually adequate and further activations are possible.

The screenshot shows the 'Recovery' tab of the Aquarius Ocean Bottom System interface. At the top, there are fields for 'localhost', 'Connect', '5304', and 'Init'. Below these are tabs for 'Pre-Deploy', 'Post-Deploy', 'Trigger Params', 'Data', 'Recovery', 'Error Messages', and 'Advanced'. The main content area displays a confirmation dialog: 'Are you sure you want to release the ballast of remote modem 5304 ?'. Below this, three steps are listed:

- Step 1: A button labeled 'Get the remote modem's unique ID' is highlighted with a red box. To its right, the unique ID 'U0060F7' is displayed.
- Step 2: A text label 'Set the burn time to' is followed by a spinner control set to '900' and the unit 'seconds', also highlighted with a red box.
- Step 3: A button labeled 'Activate the remote modem's burn wire' is highlighted with a red box.

At the bottom right of the main area is an 'Undeploy' button. The status bar at the bottom shows 'Ready', a signal strength icon, 'Range: 0m', 'XC: 77', 'SNR: 61', and 'DBV: -20'.

- Click on the **Activate the remote modem's burn wire** button to send the command to the Aquarius via acoustic. Once the command is correctly sent, the countdown is showed on the window.

This screenshot shows the same interface as the previous one, but now the 'Activate the remote modem's burn wire' button (Step 3) is highlighted with a red box. To the right of the button, a large digital display shows '894 s remaining'. The status bar at the bottom now shows 'Ready', a signal strength icon, 'Range: 0m', 'XC: 76', 'SNR: 61', and 'DBV: -20'.

 **Caution:** Do **NOT** use the “Undeploy” button at this stage.

To monitor the Aquarius during recovery, switch to the *Post-Deploy* tab and click **Status**. If the Aquarius is ascending, the reported pressure value will decrease with each status request.

 **Note:** This tool can also be used prior to deployment to verify that the burn-wire release system responds correctly to acoustic commands. Set the burn time to an appropriate duration (for example, 60 s) and verify the voltage as described in Section 9.2.5.

9.1.7. Error Messages

In the *Error Messages* tab, errors that occur during the data retrieval via acoustic link are listed. This tool is useful to identify the cause of the issue.

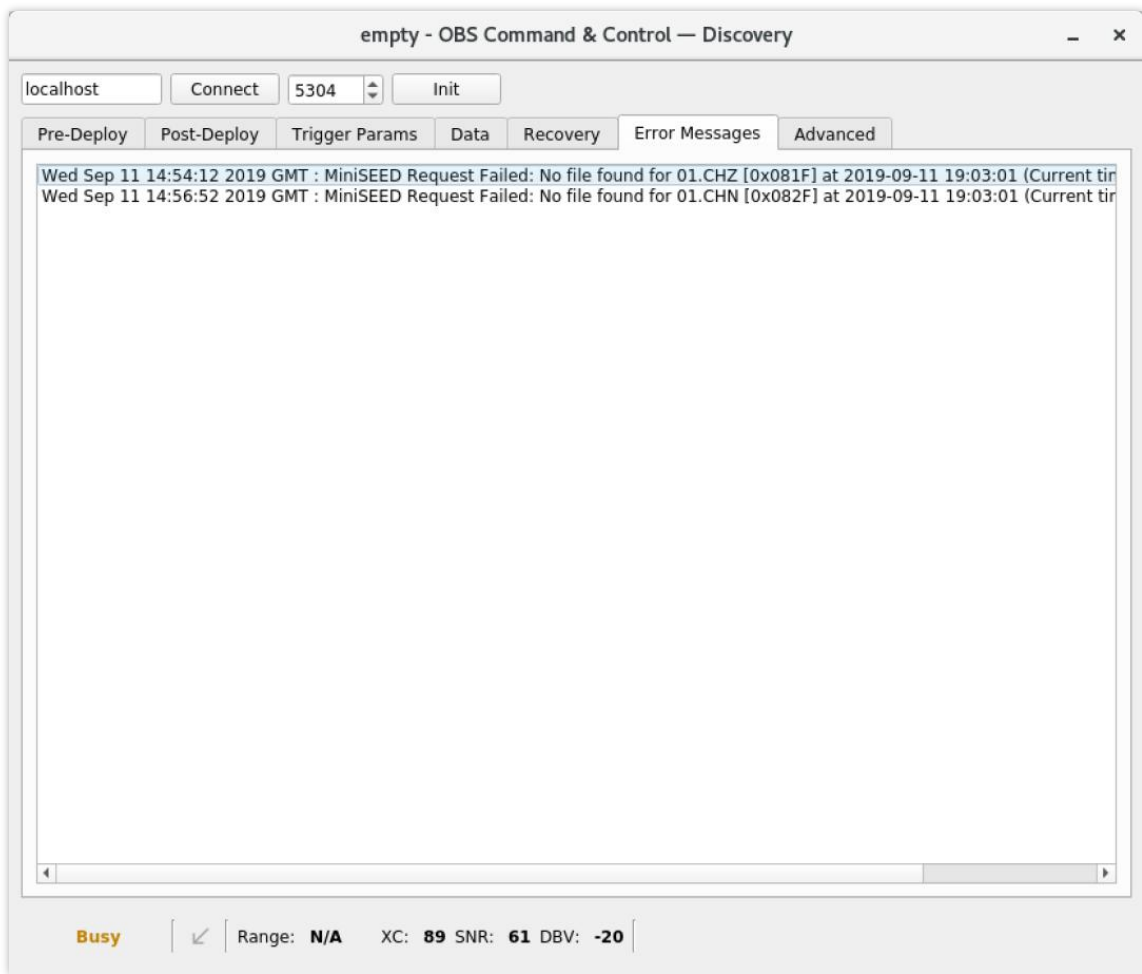

9.2. Aquarius Deployment

While the *OBS Command & Control* widget utilises the acoustic modem connected to the deck unit, the *Aquarius Deployment* widget connects to the Aquarius using the LAN.

Before the Aquarius can be safely deployed, a series of system checks must be completed to verify that the instrument is correctly configured, fully operational, and ready of autonomous operation on the seafloor. To support this process, this tool provides a guided pre-deployment checklist that leads the user through the required verification steps in a structured and repeatable manner. The *Aquarius Deployment* widget can be accessed through Discovery by right-clicking on the Aquarius entry and selecting Aquarius Deployment.

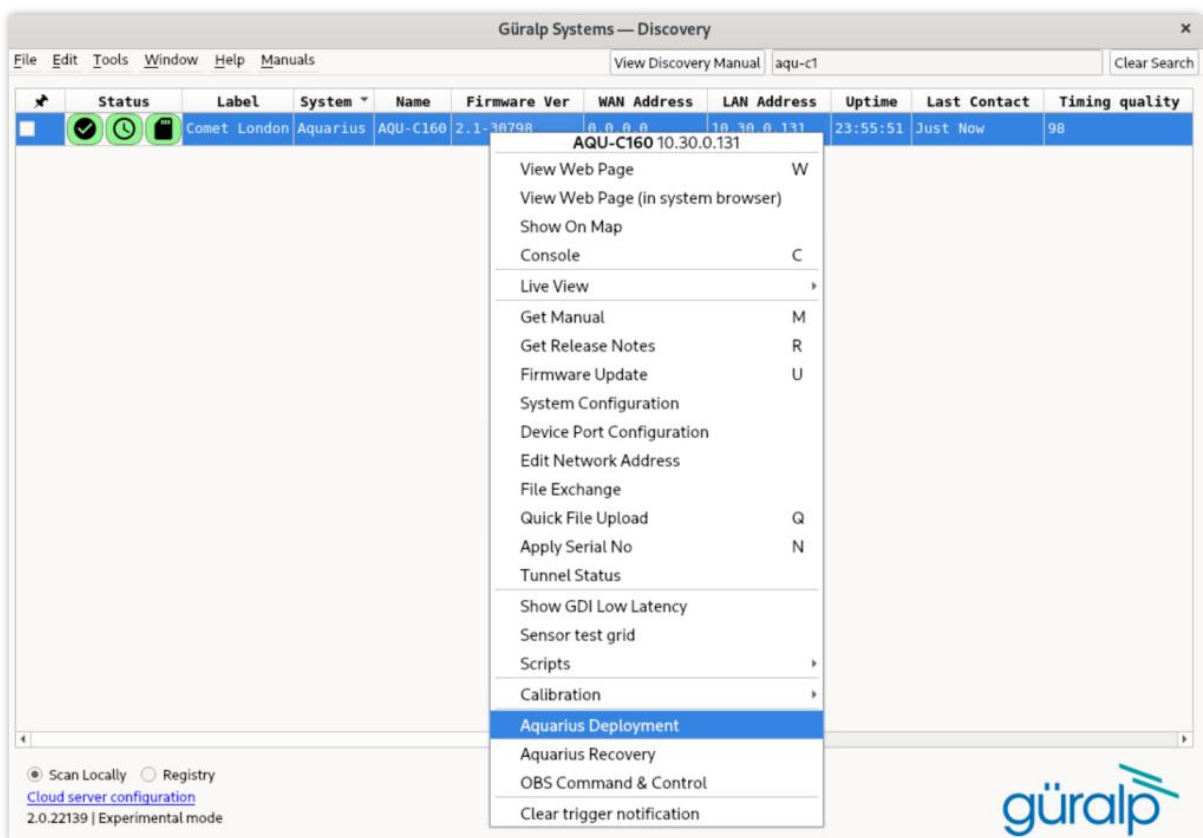

The checklist is organised into several tabs (*System Reset*, *Web Interface*, *Configuration*, *Timing*, *Storage* and *Recovery*). Within each tab, the user is prompted to review settings, confirm system states, and acknowledge required actions.

As each tab is completed, its title changes colour to indicate status:

- Incomplete tabs remain unmarked, indicating that required checks have not yet been verified.
- Complete tabs turn green, confirming that all checks within that section have been successfully acknowledged.

Aquarius Ocean Bottom System

Only once all tabs are marked green, the user should proceed with deployment. This ensures that no critical configuration or operational step is overlooked prior to release of the instrument.

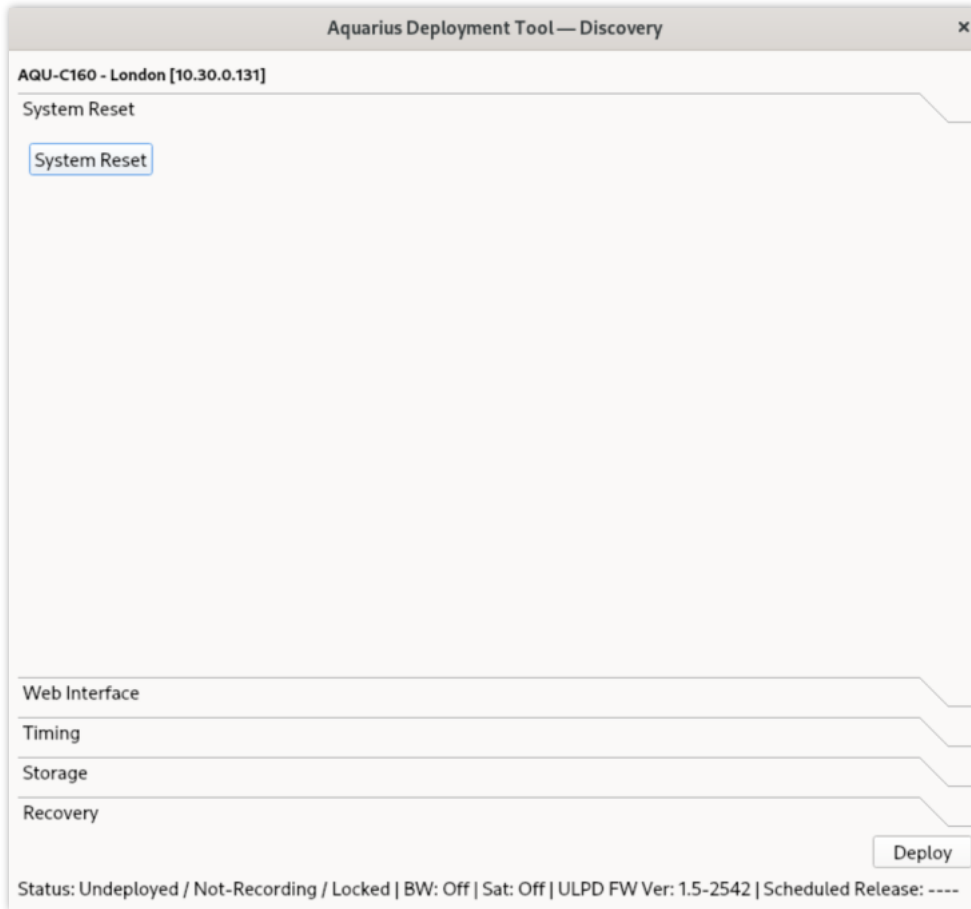

The following sections of this chapter describe each tab in detail, explaining the purpose of the checks, the expected system behaviour, and any actions required by the user. Operators should complete these steps carefully and in sequence to ensure reliable instrument performance and successful recovery after deployment.

9.2.1. System Reset

The ULPD can be reset to the **Undeployed** state and the LPC rebooted pressing the **System Reset** button. Preparing the Aquarius to a deployment, click this button to start with a clean boot of both ULPD and LPC.

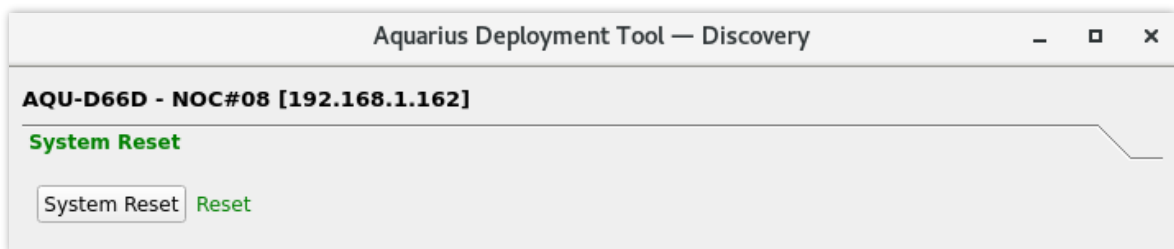

9.2.2. Web Interface

The *Web Interface* tab is used to confirm that the required configuration settings were correctly applied during instrument setup via the internal browser interface. During configuration, multiple system settings – such as timing source and recording options – are set through the web interface. This check prompts the user to review these settings and confirm they were configured according to deployment requirements.

The items to verify during this check include:

- Selection of correct timing source, i.e. PTP set to “Run always – Override GPS” (as described in Section 8.4)
- Confirmation that modem-related parameters and addresses have been noted
- Verification that the depth range at which the OBS is going to be deployed has been set for acoustic communications (as described in Section 9.1.2)
- Confirmation that recording channels have been reviewed
- Confirmation that the battery level is adequate for the planned deployment duration (as described in Section 5.5).

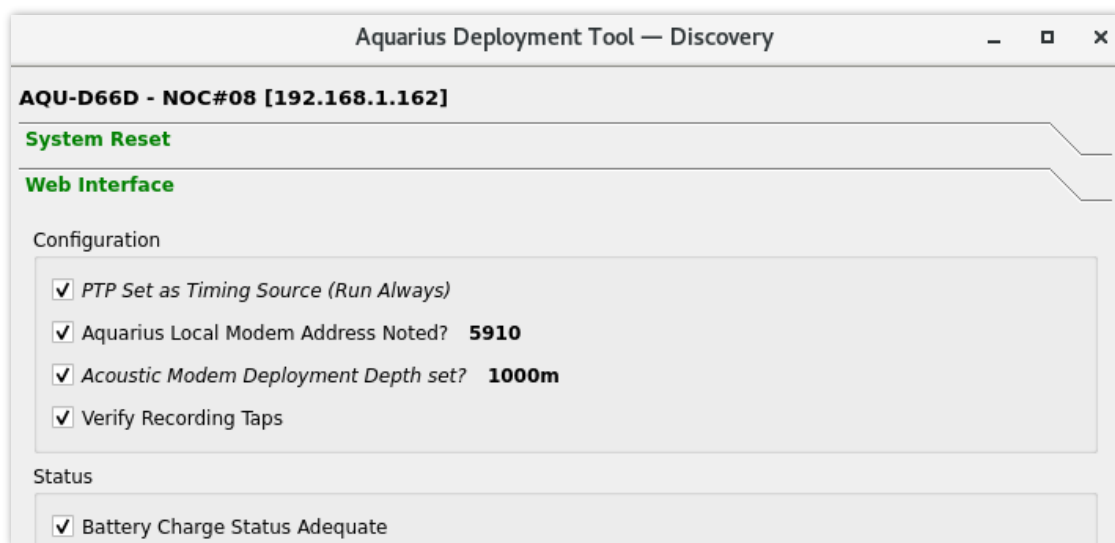

Deployment should only continue once this check is completed and the tab is marked green.

9.2.3. Timing

The *Timing* tab verifies that the Aquarius’ internal clock is correctly synchronised to the external timing source (PTP) and that the timing system is stable. Through this tab, the user can verify the following:

- **PTP status**

This field indicates whether the instrument is locked to the PTP master. Before deployment, PTP should reach 100% stability and the reported offset should be 0 ms

- **Internal clock performance**

This section reports the performance of the internal PLL (phase-locked loop), which disciplines the instrument’s internal oscillator to the external timing reference.

- **Control voltage monitoring**

Control voltage parameters provide additional insights into the stability of the internal oscillator. These values are expressed in digital counts.

- **Locking Progress**

This bar shows the current status of the clock-locking process. The user must ensure that the system has completed its locking sequence before deployment.

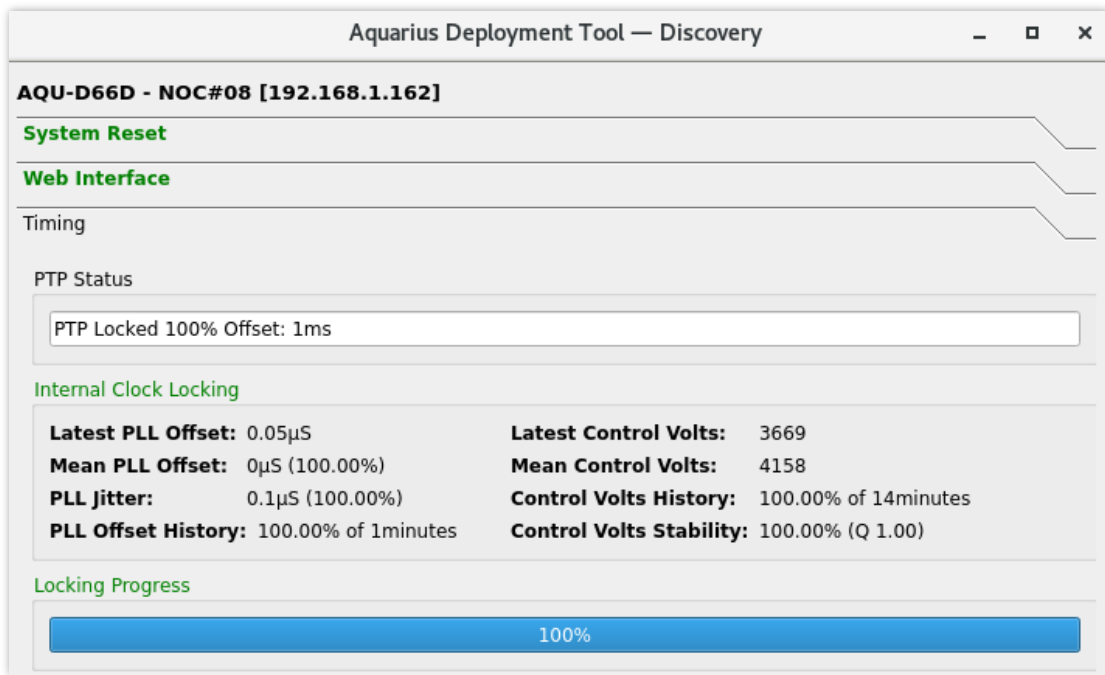

 **Note:** The locking progress takes at least 14 minutes to complete.

Deployment must not proceed if timing lock has not been achieved or if the reported parameters indicate instability.

9.2.4. Storage

The *Storage* tab verifies that the instrument’s microSD cards are present, usable, and have sufficient capacity to record data for the planned deployment duration. This check ensures that seismic data will be reliably recorded until recovery.

The *Storage* field provides a summary of the current status of the internal and external SD cards. The users must review this information to confirm that all storage devices are correctly detected, ready for use, and that sufficient free space remains to accommodate the expected data volume.

Aquarius Ocean Bottom System

The **Format Cards** button allows the user to re-initialise the SD cards with a quick format. Formatting can be performed to ensure a clean recording environment prior to a new deployment.

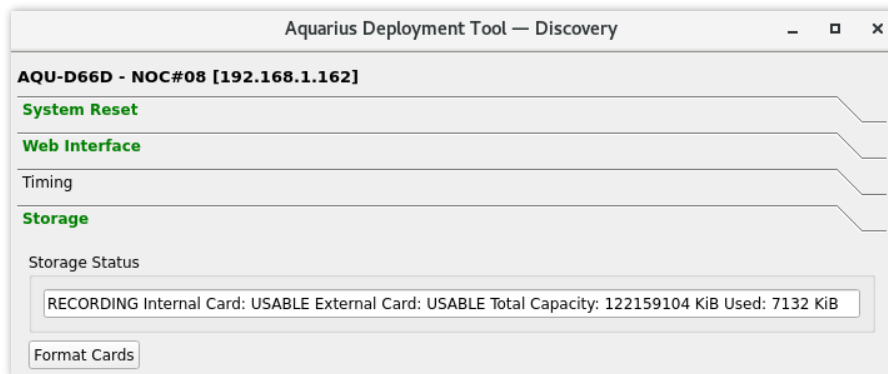

Deployment must not proceed if SD cards are missing, not recording, or lack adequate free space.

9.2.5. Recovery

The *Recovery* tab verifies that the recovery-related systems are correctly operational prior to deployment. These systems are critical to locating and recovering the Aquarius at the end of the deployment and must be confirmed before proceeding. Functional tests for the satellite tracker, visual indicators, and ballast release mechanism are available.

- **Satellite Tracker and LED Strobe**

Where flashing LED beacons and satellite tracker are fitted, they can be switched on manually with the **Test** button. Pressing this will cause the recovery aids to act as if the Aquarius has resurfaced: the LEDs will flash (as long as the ambient light level is low enough) and the satellite tracker will engage. This feature should be switched off before deployment.



Note: If the Aquarius is not fitted with an LED beacon or satellite tracker and instead uses alternative recovery aids (such as **Apollo** and/or **Xeos** satellite beacons), the **Test** button can still be pressed twice to toggle the recovery test on and off. In this case, no visible response will occur, but the check will be marked as completed.

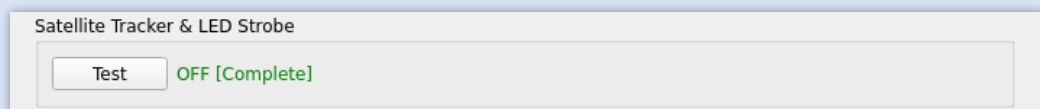

- **Burn Wire Ballast Release**

The ballast release mechanism can be tested by clicking on the relevant **Test** button. During the test function for the burn wire release, the system applies a voltage across the burn wire output terminals to verify correct operation of the release electronics. This is a

Aquarius Ocean Bottom System

non-destructive electrical verification: in air, the absence of seawater as an electrolyte prevents current flow between the burn wire and cathode, so the wire does not corrode or break.

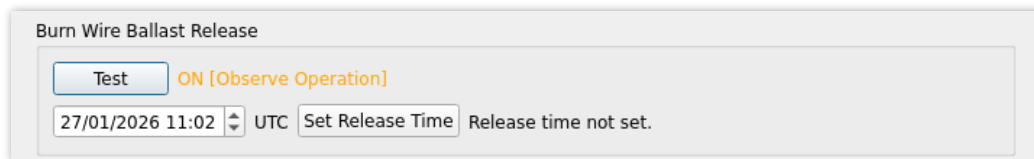

Verification of the applied voltage may be performed while the test is **ON** using a multimeter connected across the burn wire terminals (see photo below). This confirms electrical continuity and correct operation of the release driver circuitry without activating the physical release mechanism.

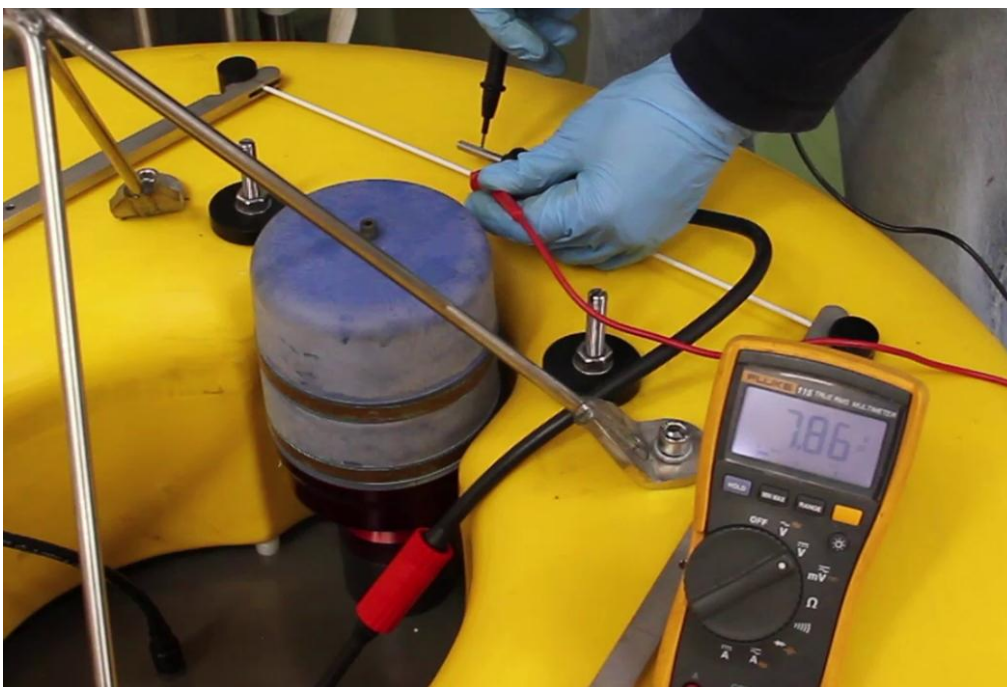

Additionally, a ballast release timer can be configured to trigger automatically shortly after the Aquarius has landed on the seafloor. This function provides a safeguard during deployment by ensuring that the instrument will resurface if acoustic communication cannot be established after descent. In fact, the user should verify acoustic communication using the acoustic modem and dunker while the instrument is descending in the water column.

The user must specify the desired release time and select **Set Release Time** to activate the timer. The release time should initially be set to a short interval after the expected seafloor landing time (with a minimum of 1 hour).

If acoustic communication is still successfully established once the instrument is on the seafloor, the user should update the release time remotely to the intended recovery date (for example, after one year). If communication cannot be established, the pre-set release timer will cause the instrument to release its ballast and resurface while the deployment vessel is still in the vicinity, allowing immediate recovery and redeployment.

 **Caution:** It is essential that the user updates the release time once reliable acoustic communication with the Aquarius has been established on the seafloor. The release time can be updated either in the *Aquarius Deployment* widget or via the *Post-Deploy* tab in the *OBS Command & Control* widget. Failure to update the release time will result in the instrument releasing its ballast and resurfacing prematurely.

After the recovery aids have been tested and the backup release time set, the tab will be shown as green.

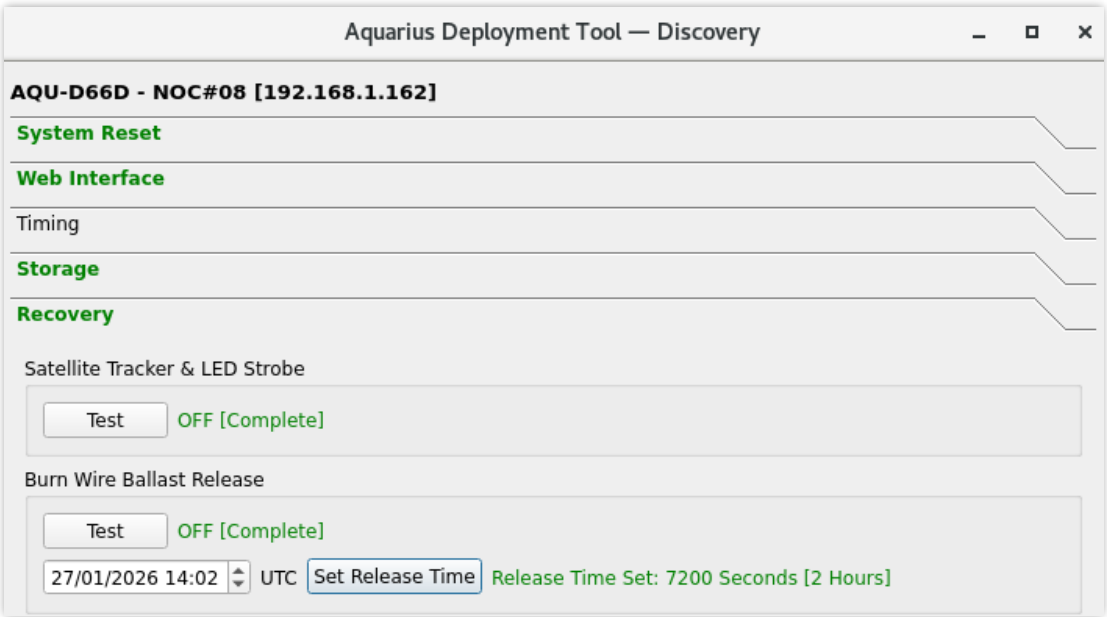

9.2.6. Deployment

Once all tabs have been completed and their section names turn green, the Aquarius is ready to be placed in **Deployed** mode by clicking the **Deploy** button. If any tab is not green, a confirmation dialog will appear asking whether you wish to proceed with the deployment.

In this state the system is in low power mode, the clock is free running, the Aquarius starts recording the FR channels in the volatile memory (RAM) of the ULPD and shuts down the LPC.

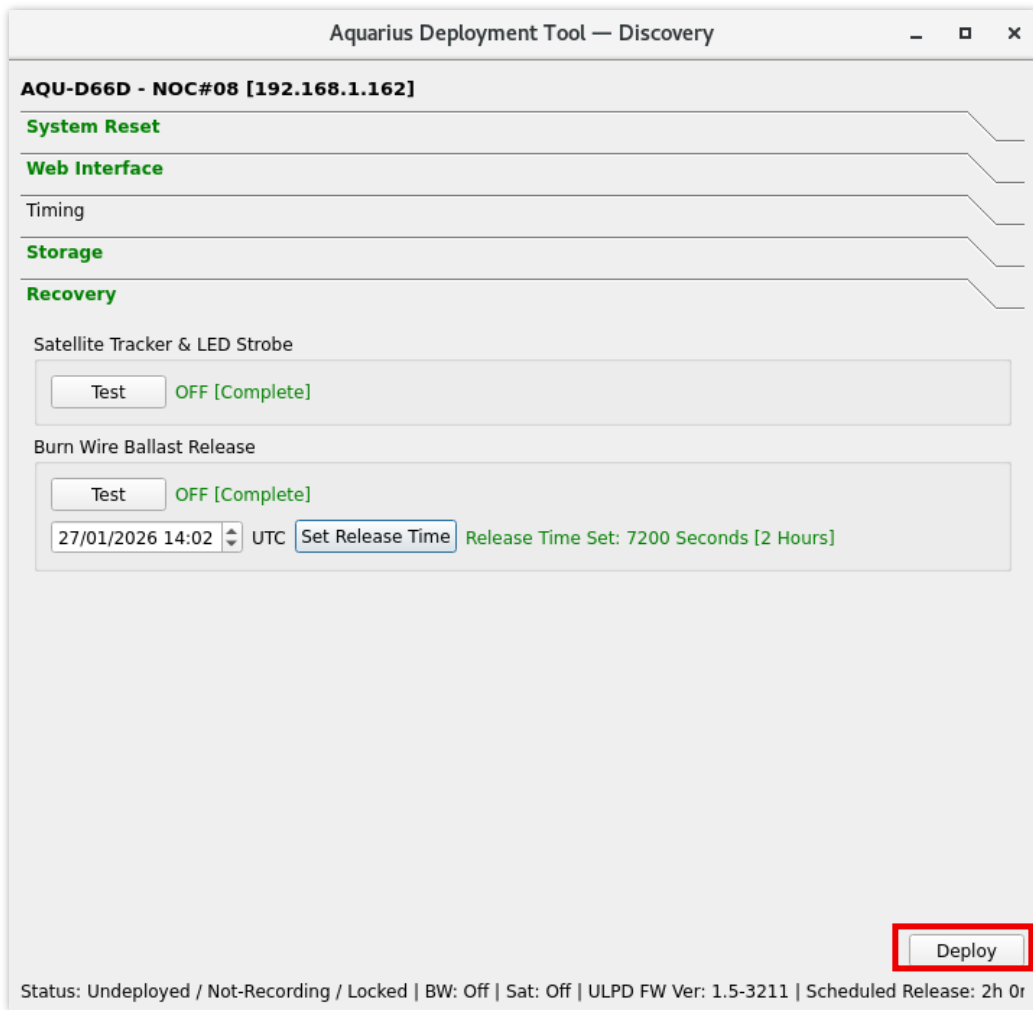

 **Caution:** Once the Aquarius is in deployed state, the Ethernet and serial cable can be disconnected from the OBS top lid. Place the SubConn 13-way connector dummy cap and screw the locking sleeve down. Check also connection of the accessory and Burn-Wire cable by the 8-way Subconn Mini series connector. Check that all the other caps have been properly screwed down with all the O-rings in place.

9.3. Aquarius Localisation

The **Locator** widget can be used to determine the location of the Aquarius once it reaches the seabed or to monitor its drift during its free fall, monitor the trajectory of the boat as it travels, load and visualize previous data.

Open Discovery and the **OBS Command & Control** widget. Verify the correctness of the IP address and use the **Connect** button on top of the window to establish the connection. Keeping the **OBS Command & Control** window open, click on menu **Tools** → **OBS** → **Locator** to open the “OBS Locator” widget.

Aquarius Ocean Bottom System

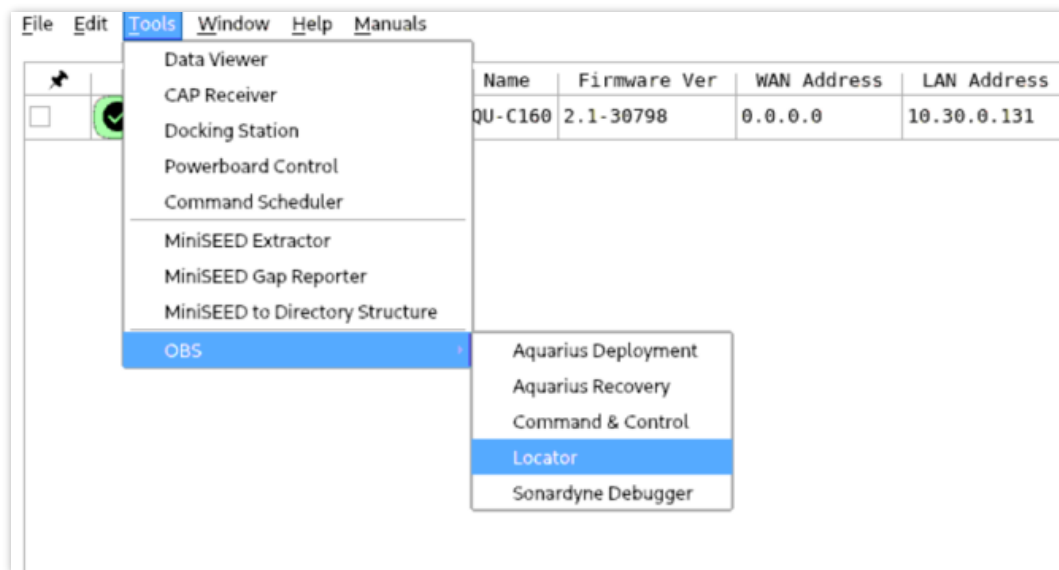

9.3.1. Overview

The *Locator* widget can:

- Ping (manually or automatically) the acoustic modem and automatically calculate the slant range from the ping return time;
- Request the depth of the Aquarius, resolved by the Keller pressure sensor;
- Automatically plot surface circles indicating the area of location of the Aquarius;
- Track boat movements by plotting its relative position every 5 seconds;
- Manually adjust the depth of the Aquarius, if correction is needed;
- Set the value for the speed of sound in water;
- Save data log files;
- Load and visualise previous log files.

9.3.2. Locating Aquarius

Before you continue, make sure a successful connection has been established (see Section 9.1.1), i.e. the modem state in the status bar says **Ready**.

Aquarius Ocean Bottom System

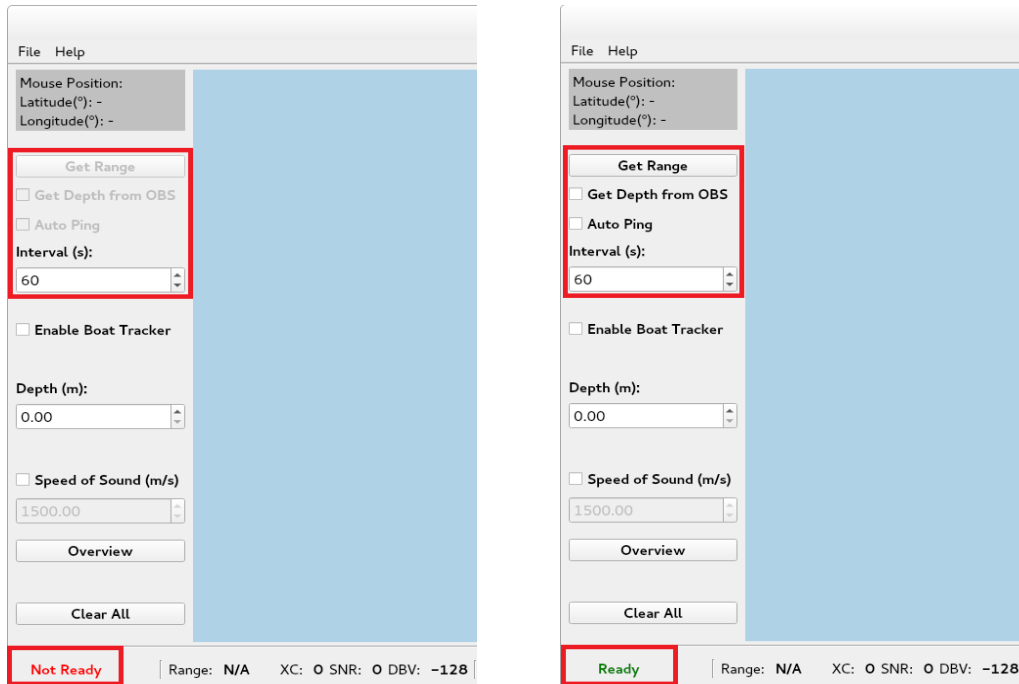

9.3.2.1. Pinging the bottom unit

Pinging the acoustic modem could be done either manually or automatically. For manual control, click on **Get Range** button. Alternatively, a timer can be set, on which timeout a ping will be sent. The slant range between the boat and the unit is calculated from the Turn-Around-Time.

If “Get Depth from OBS” box is checked when a ping is sent, the pressure value from the Keller pressure sensor is also requested. The value of the depth will automatically get updated in the “Depth (m)” spin-box.



Note: Requesting and transmitting data from the Keller pressure sensor uses more power than pinging the acoustic modem. Uncheck the box once the unit reaches the seabed.

Once the slant range and depth are calculated, a circle with a radius equal to the surface distance between the boat (*black cross*) and the Aquarius is plotted.

Aquarius Ocean Bottom System

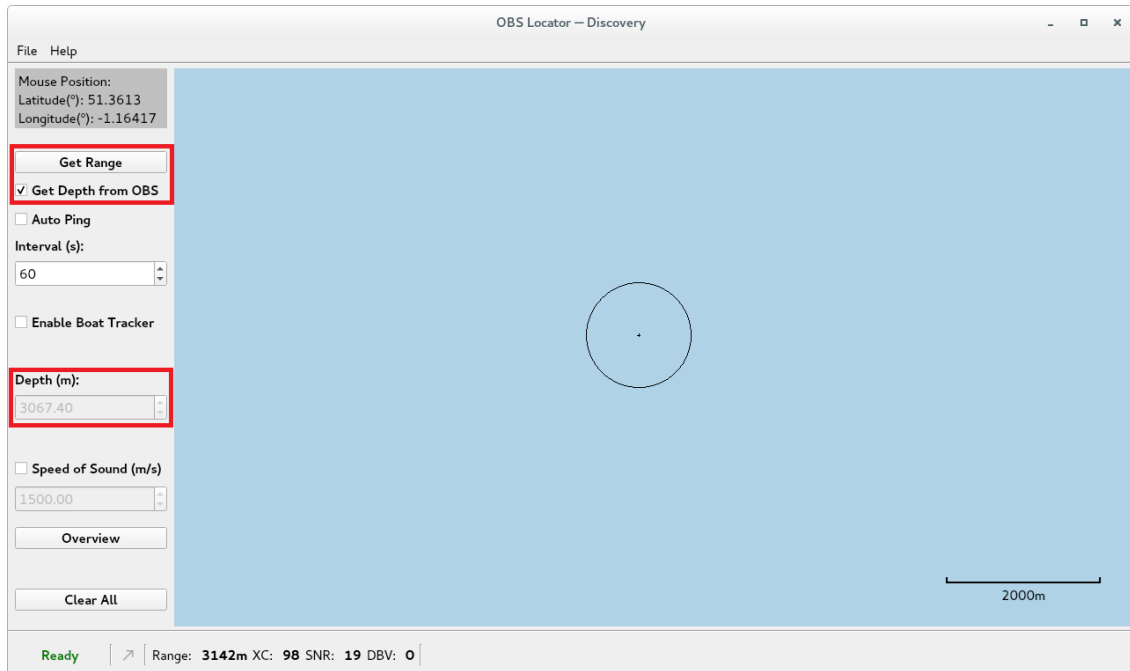

9.3.2.2. Recording Aquarius location

Use the “Depth (m)” to manually adjust the depth of the unit, if the circles fail to intersect in a single point. All circles will be dynamically replotted with a radius corresponding to the new depth.

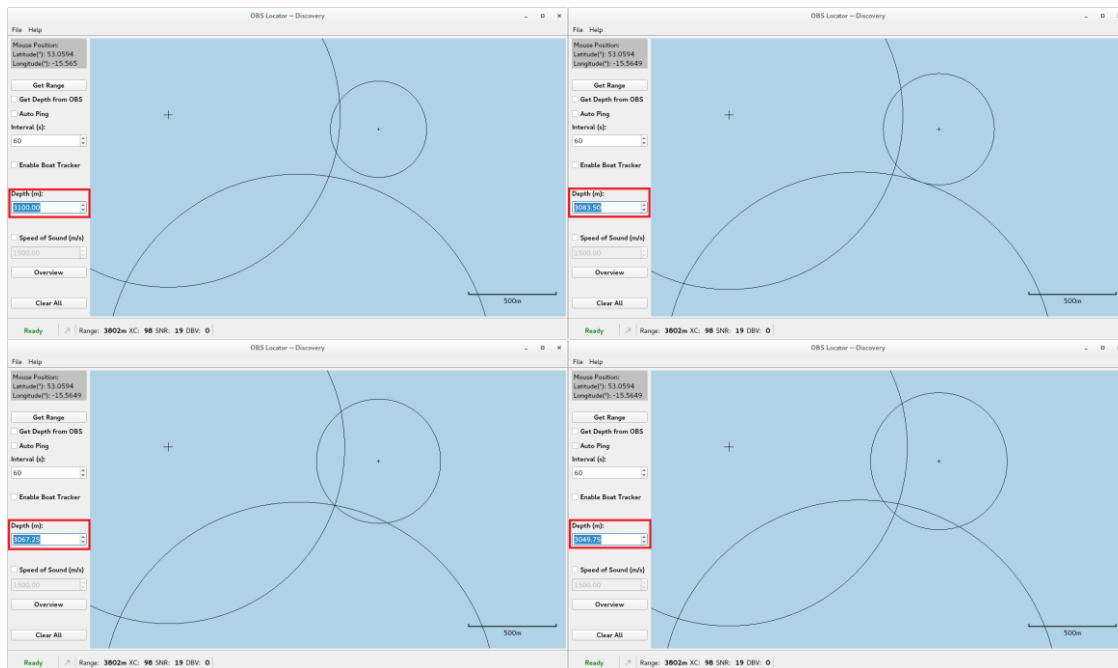

Mark the Aquarius location (*blue* cross) by zooming in and double-clicking on the intersection point of the circles.

Aquarius Ocean Bottom System

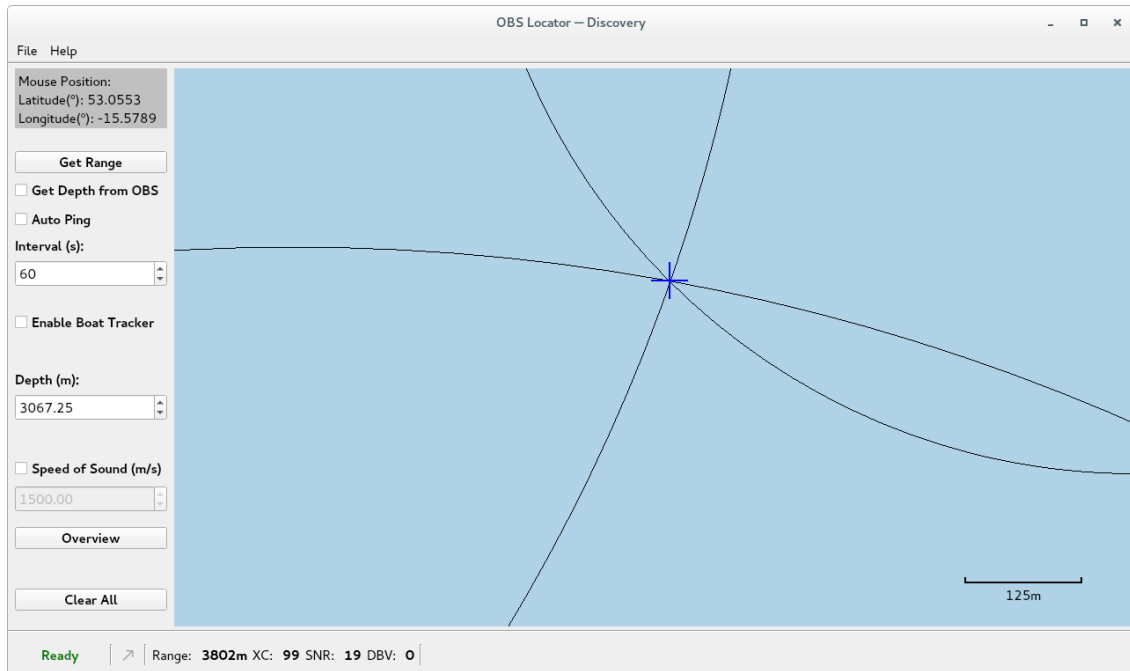

9.3.2.3. Boat Tracker

The boat tracking feature is activated when “Enable Boat Tracker” is checked. It plots the relative location of the boat (*red* triangle) and its trajectory every 5 seconds. It is intended to provide an overview of the boat movement when travelling during the triangulation process.

 **Note:** None of these locations are recorded in the log file.

 **Caution:** This tool is not intended for navigation use.

Aquarius Ocean Bottom System



9.3.2.4. Speed of Sound

The default value for the speed of sound used to calculate the slant range from the ping return time is 1,500 m/s. To change it, check the “Speed of Sound (m/s)” box and enter a different value. The change will also affect the already plotted circles.

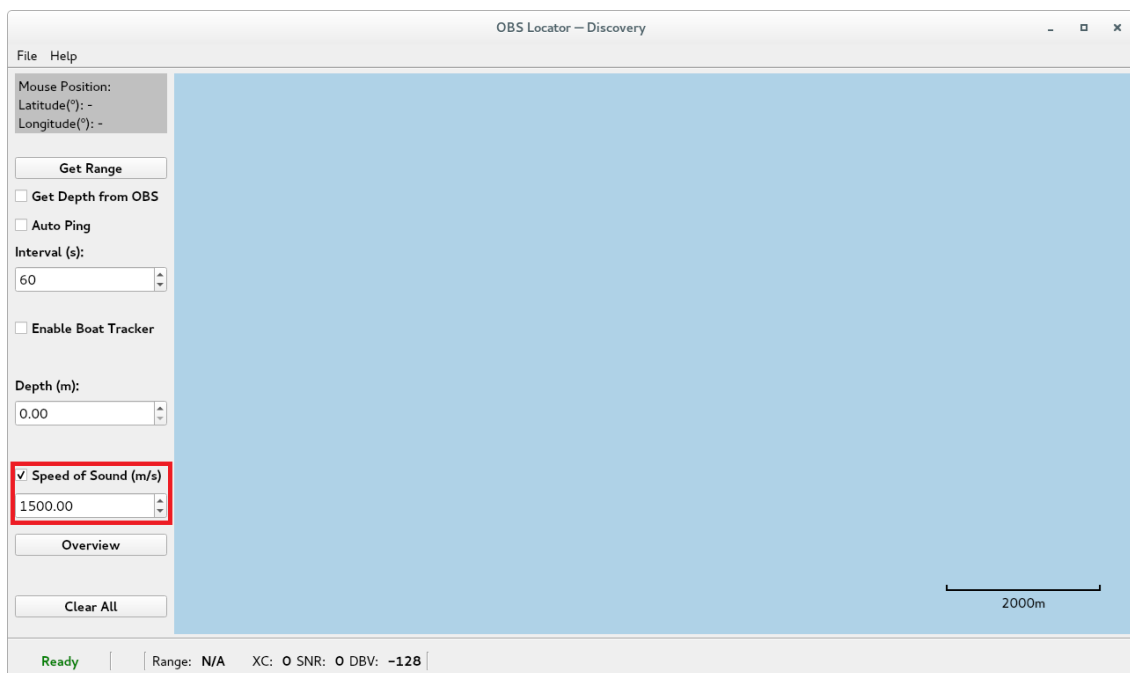

9.3.2.5. Map Navigation

“Mouse Position” indicates the location on the map under the centre of the cursor. It is disabled by default until an event is recorded and plotted.

Use the **Overview** button to zoom the current view of the map to fit all graphical items.

Aquarius Ocean Bottom System

Use the **Clear All** button to clear all graphical items from the map.

The bar in the bottom right corner of the map indicates the current map scale.

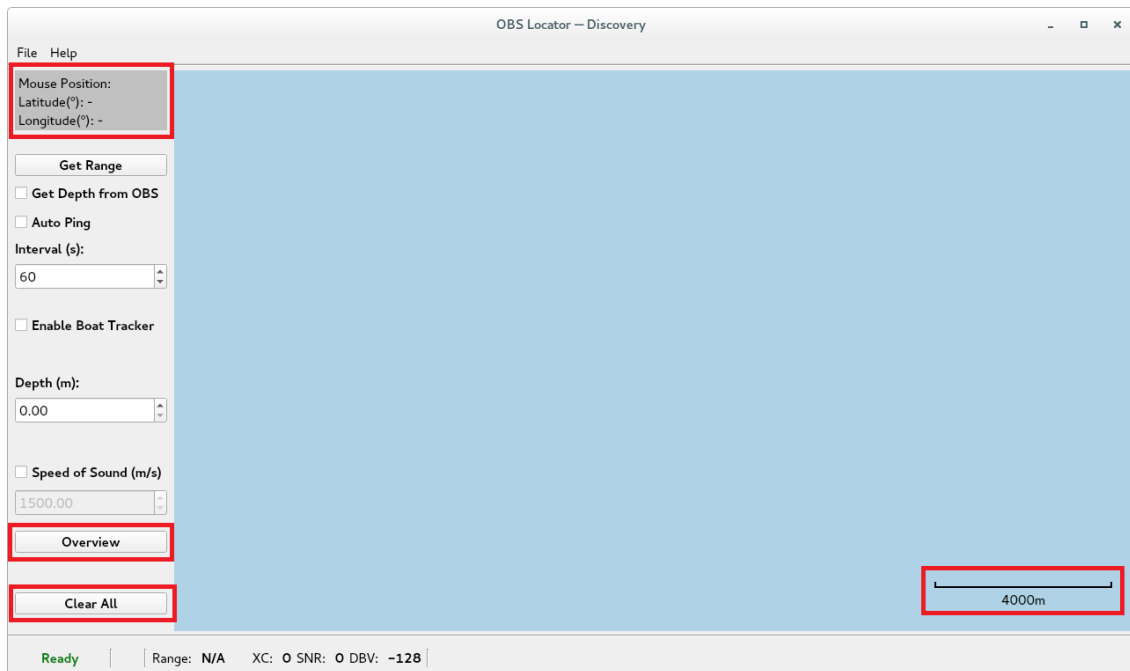

9.3.3. Data Processing



Note: None of the modifications described below are automatically saved. Once finished, save the changes to a log file via **Save As** button in the “File” menu or Ctrl + S.

9.3.3.1. Add Circle

To add a new circle manually, right-click and select “Add Circle”. In the “Add/Edit” box, enter the desired location (latitude and longitude), range, OBS depth and speed of sound and click on **Add**.

Aquarius Ocean Bottom System

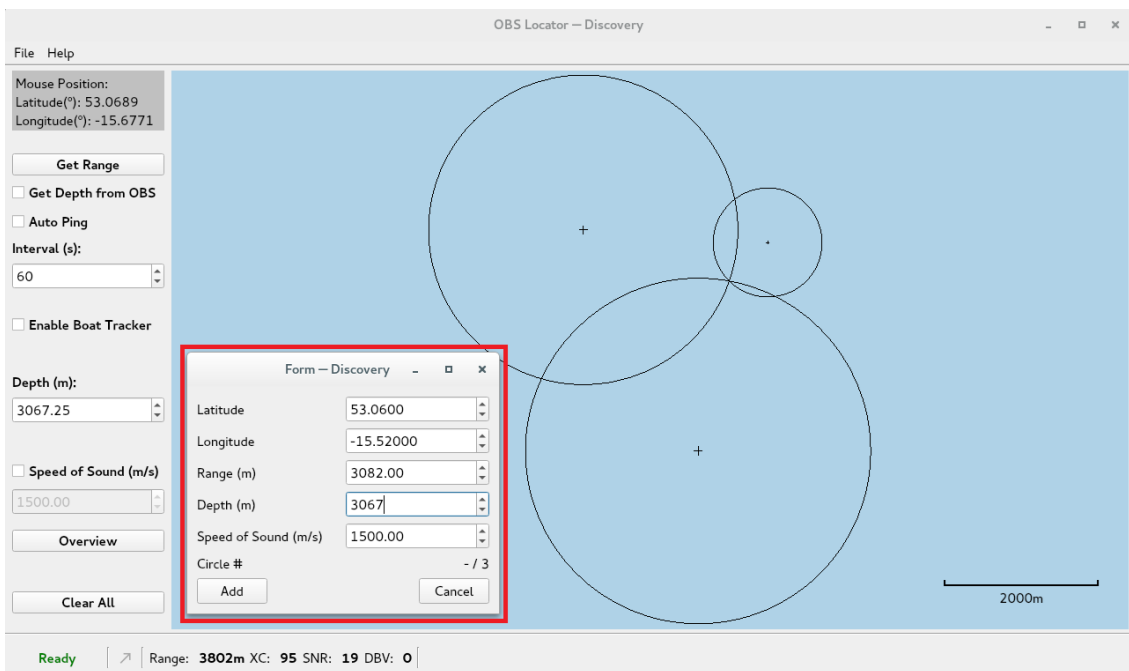
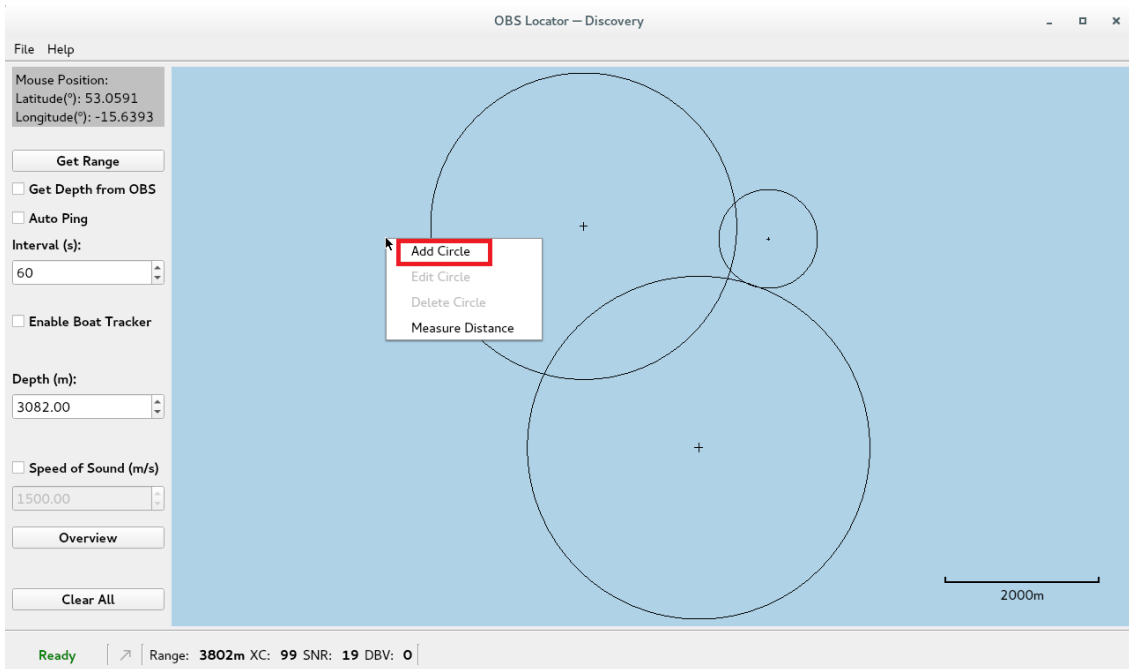

Aquarius Ocean Bottom System

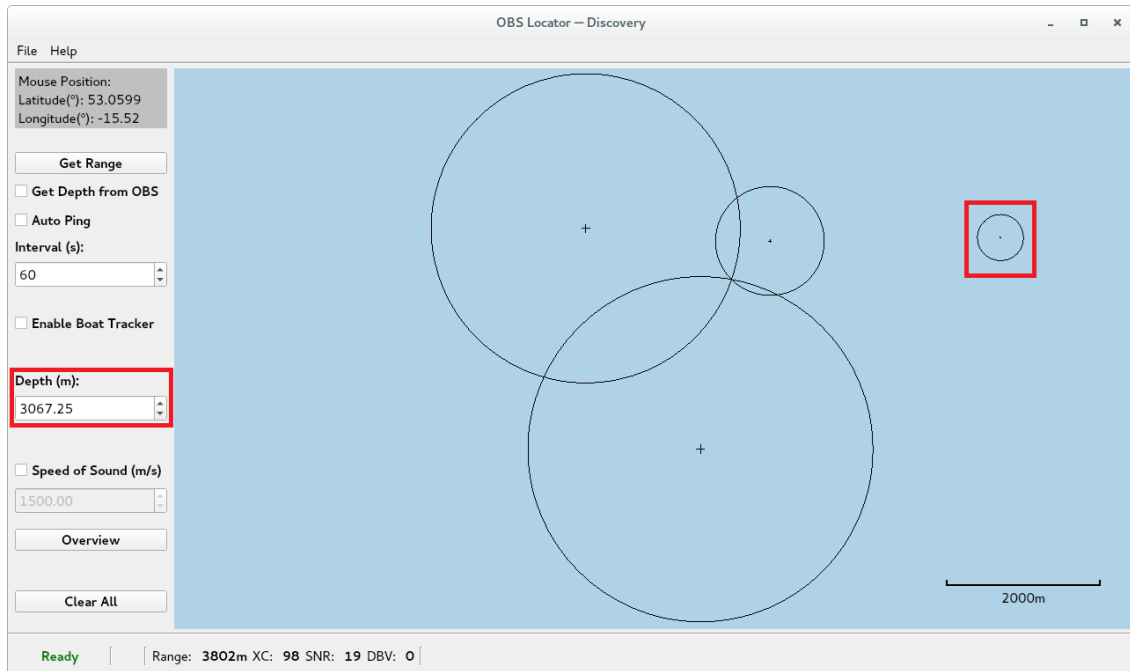

 **Note:** Manually added circles will be automatically painted using the value of the current depth rather than their own depth. In cases when the value of the current depth is greater than the value of the slant range, this circle will not be visible until the current depth is less than the range.

9.3.3.2. Edit Circle

To edit an existing circle, right-click on it and select “Edit Circle”. The circle to be edited will get highlighted and an “Add/Edit” box will open with the current parameters of this circle. To change any of them, simply use the spin-box arrows or the keyboard. Changes apply immediately.

Aquarius Ocean Bottom System

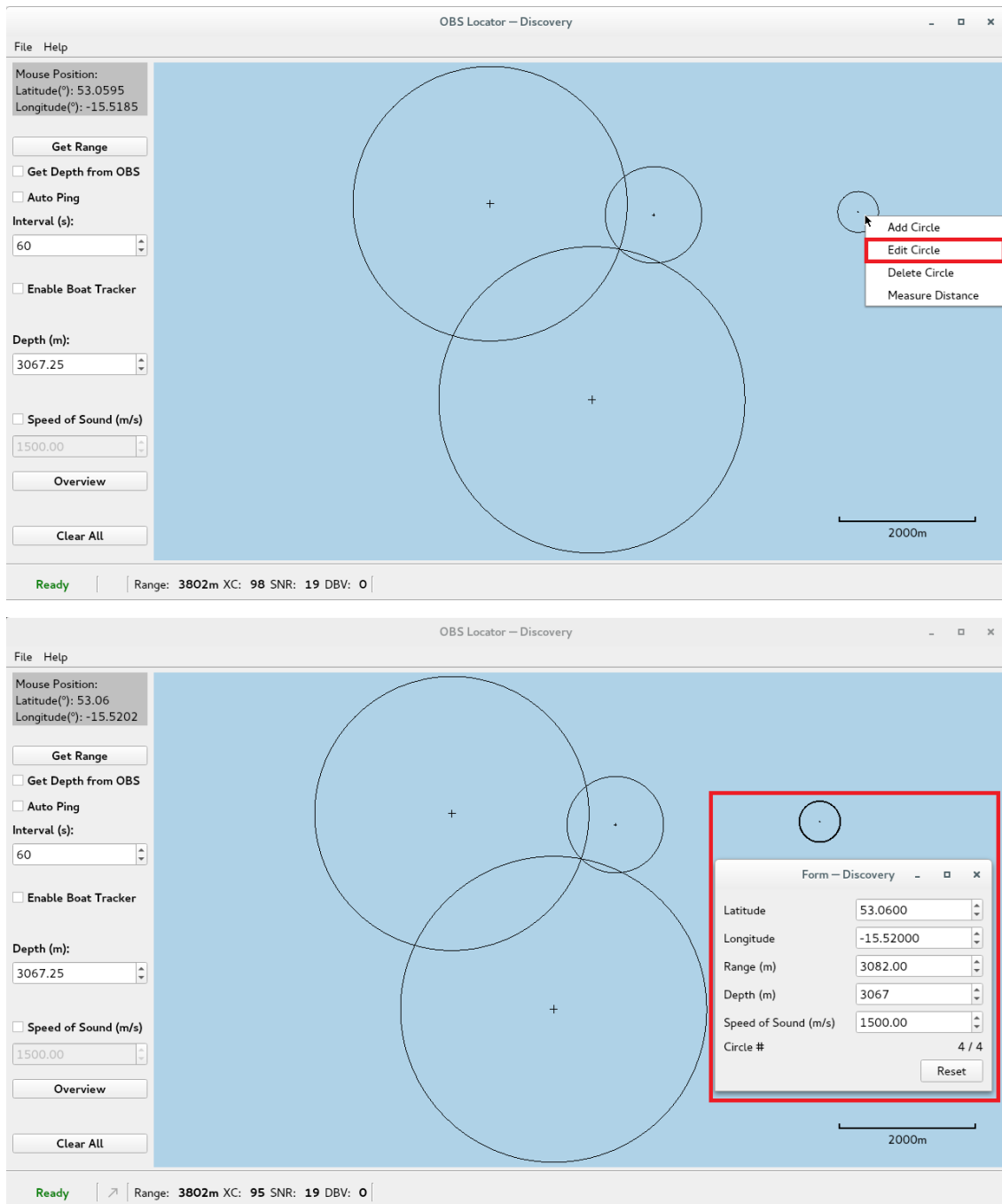

9.3.3.3. Delete Circle

To delete an existing circle, right-click on it and select "Delete Circle".

Aquarius Ocean Bottom System

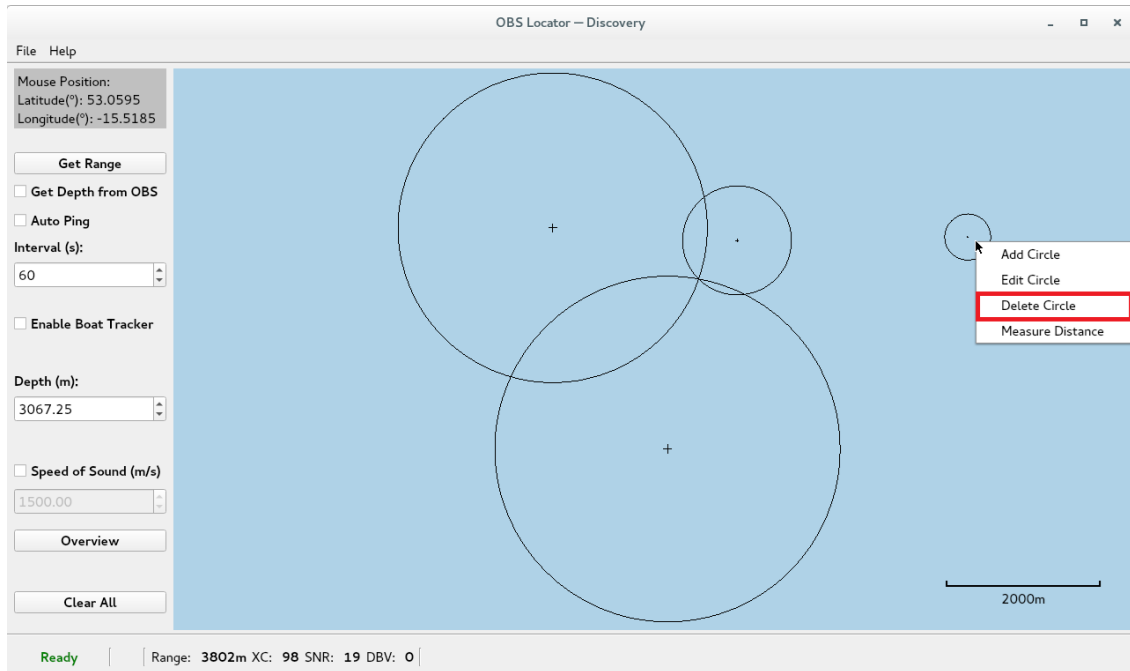

9.3.3.4. Measure Distance

“Measure Distance” tool is useful for measuring the distance between two or multiple points on the map. To use it, right-click on the map and select “Measure Distance”.

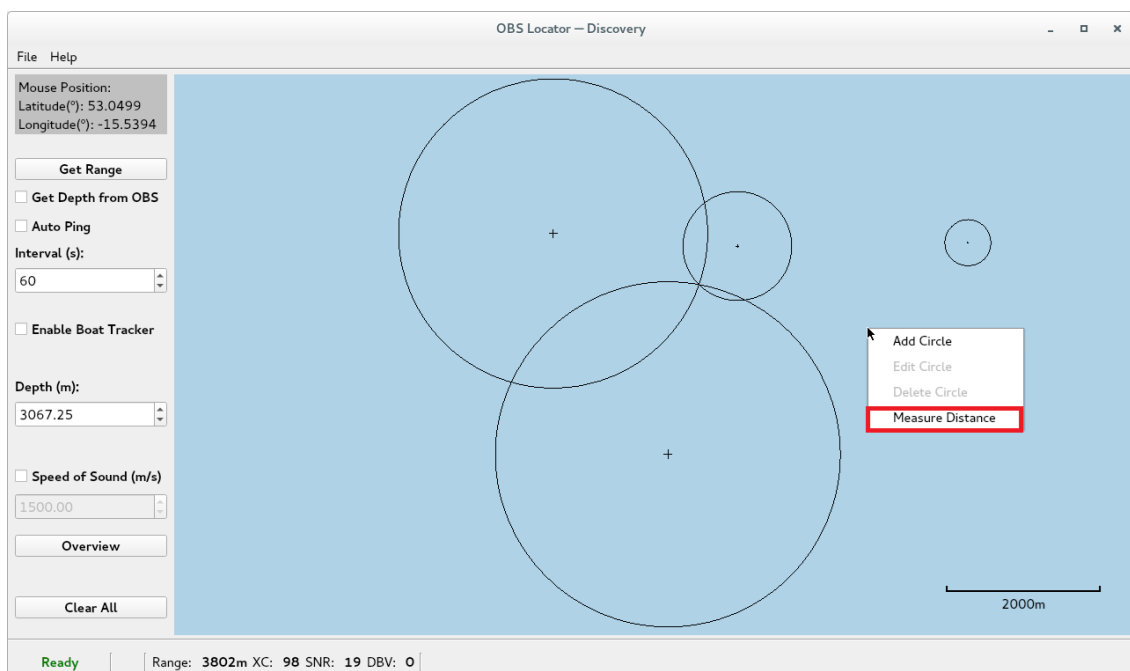

To add a new point, double-click on the map and a white dot will mark it. The distance next to each dot indicates the total distance between that point and the first one.

Aquarius Ocean Bottom System

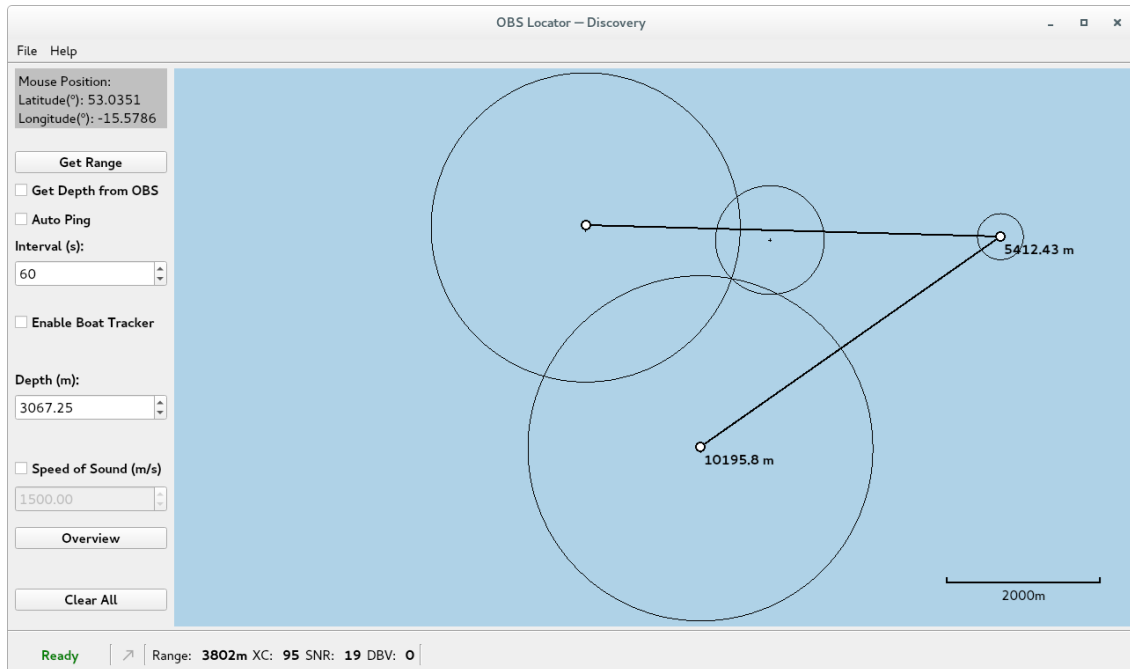

To delete an existing point, click on it. If it is a middle point, the distance between its neighbours is measured instead and the total distance for each point gets updated. If it is the last point, the last distance segment is removed. The first point cannot be deleted unless all other points are deleted first.

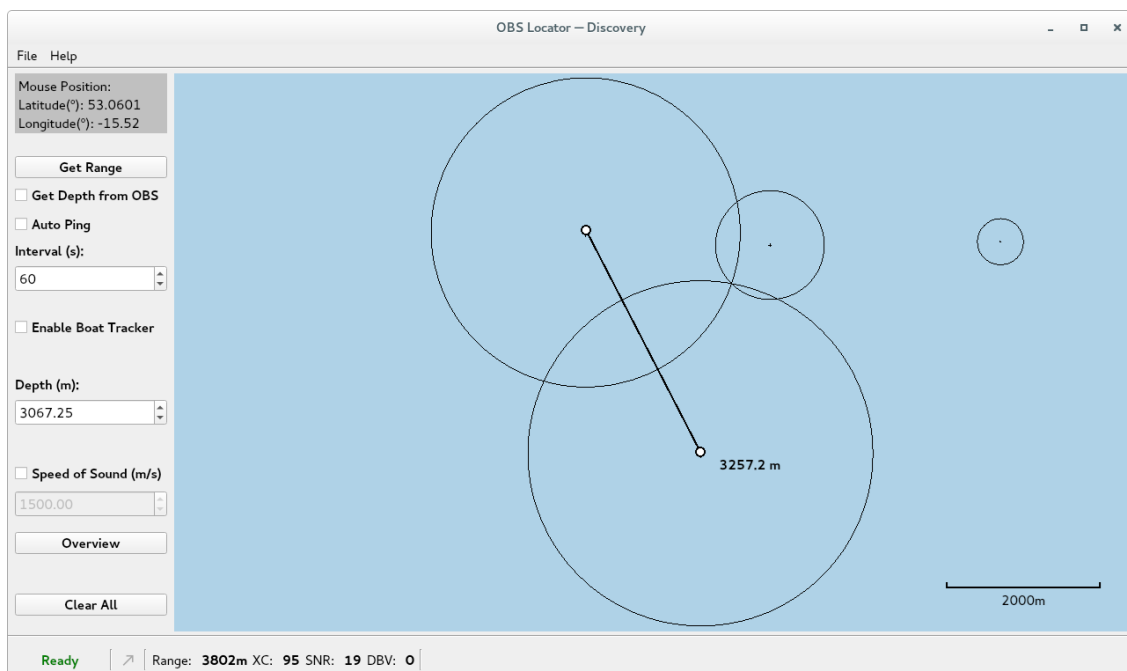

To delete all points at once, right-click on the map and select "Clear Measurement"

Aquarius Ocean Bottom System

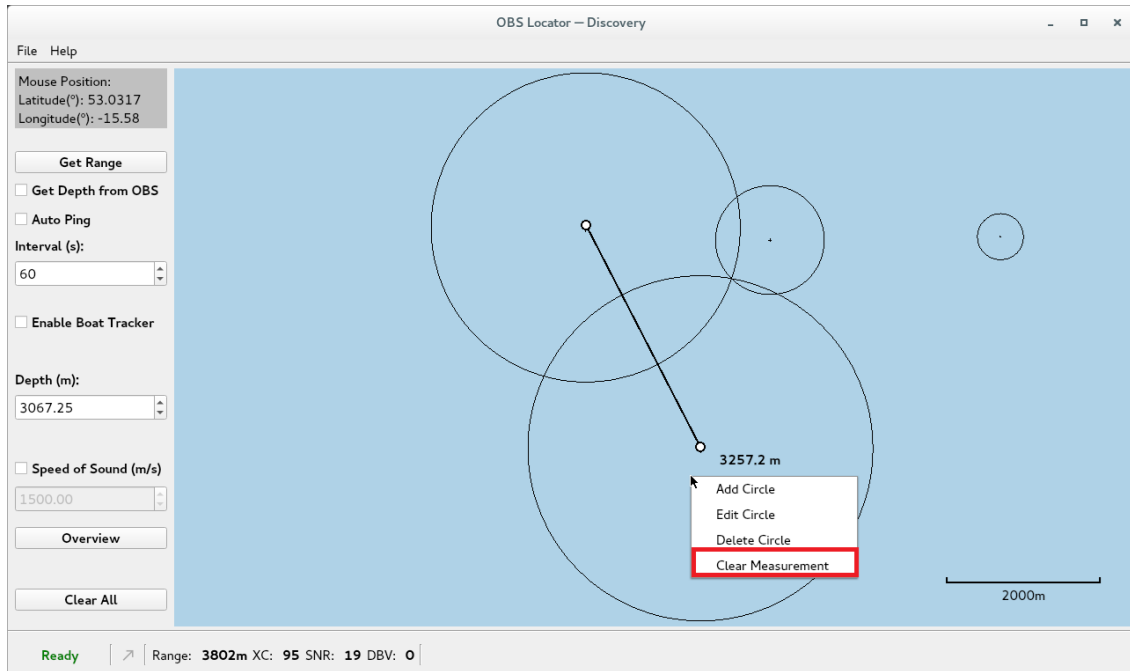

9.3.4. Log Files

There are two types of data files generated by the *OBS Locator*: standard log file (.log) and “Boat Tracker” log file (.btr). The former file stores the parameters of each circle or the location of the OBS, while the latter file stores the location of the boat while the “Boat Tracker” is enabled. Both files are automatically generated and updated; and could be loaded at the same time later on.

9.3.4.1. File Formats

The file name of either file type is the **current date** in *dd-mm-yyyy* format and is saved in the application configuration directory:

MacOS	"~/Library/Preferences/Guralp Systems/Discovery/obs_locator/"
Windows	"C:/Users/<USER>/AppData/Local/Guralp Systems/Discovery/obs_locator/"
Linux	"~/.config/Guralp Systems/Discovery/obs_locator/"

The data in the standard .log file has the following formats:

Date (dd-mm-yyyy), Time (hh:mm:ss), Boat Location (Lat,Lon), Turn-Around-Time (us), Slant Range (m), OBS Depth (m), Speed of Sound (m/s)

Date (dd-mm-yyyy), Time (hh:mm:ss), OBS Location: Lat,Lon, Depth: xxxx (m)

Aquarius Ocean Bottom System

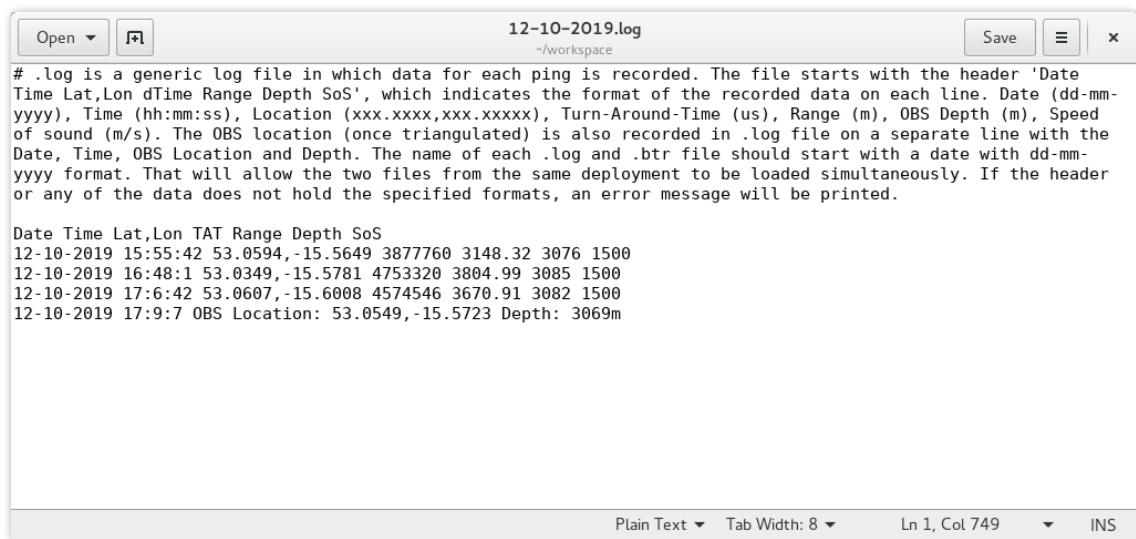

```
# .log is a generic log file in which data for each ping is recorded. The file starts with the header 'Date
Time Lat,Lon dTime Range Depth SoS', which indicates the format of the recorded data on each line. Date (dd-mm-
yyyy), Time (hh:mm:ss), Location (xxx.xxxx,xxx.xxxxx), Turn-Around-Time (us), Range (m), OBS Depth (m), Speed
of sound (m/s). The OBS location (once triangulated) is also recorded in .log file on a separate line with the
Date, Time, OBS Location and Depth. The name of each .log and .btr file should start with a date with dd-mm-
yyyy format. That will allow the two files from the same deployment to be loaded simultaneously. If the header
or any of the data does not hold the specified formats, an error message will be printed.

Date Time Lat,Lon TAT Range Depth SoS
12-10-2019 15:55:42 53.0594,-15.5649 3877760 3148.32 3076 1500
12-10-2019 16:48:1 53.0349,-15.5781 4753320 3804.99 3085 1500
12-10-2019 17:6:42 53.0607,-15.6008 4574546 3670.91 3082 1500
12-10-2019 17:9:7 OBS Location: 53.0549,-15.5723 Depth: 3069m
```

The data in the “Boat Tracker” (.btr) file has following format:

Date (dd-mm-yyyy), Time (hh:mm:ss), Location (Lat,Lon)

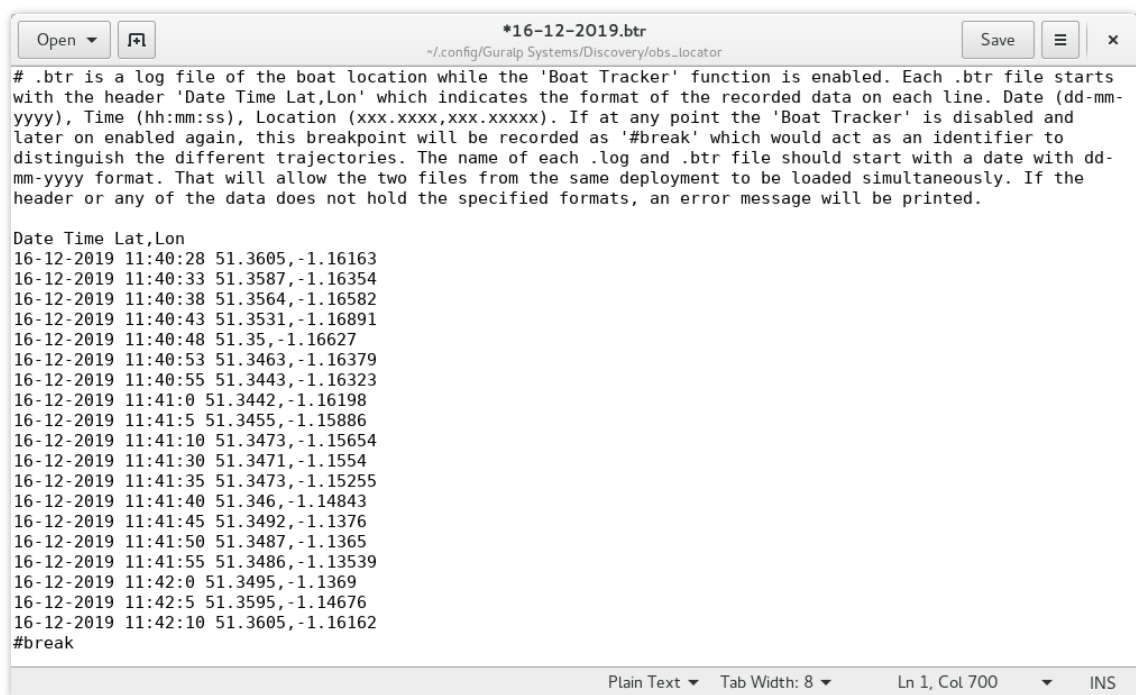

```
# .btr is a log file of the boat location while the 'Boat Tracker' function is enabled. Each .btr file starts
with the header 'Date Time Lat,Lon' which indicates the format of the recorded data on each line. Date (dd-mm-
yyyy), Time (hh:mm:ss), Location (xxx.xxxx,xxx.xxxxx). If at any point the 'Boat Tracker' is disabled and
later on enabled again, this breakpoint will be recorded as '#break' which would act as an identifier to
distinguish the different trajectories. The name of each .log and .btr file should start with a date with dd-
mm-yyyy format. That will allow the two files from the same deployment to be loaded simultaneously. If the
header or any of the data does not hold the specified formats, an error message will be printed.

Date Time Lat,Lon
16-12-2019 11:40:28 51.3605,-1.16163
16-12-2019 11:40:33 51.3587,-1.16354
16-12-2019 11:40:38 51.3564,-1.16582
16-12-2019 11:40:43 51.3531,-1.16891
16-12-2019 11:40:48 51.35,-1.16627
16-12-2019 11:40:53 51.3463,-1.16379
16-12-2019 11:40:55 51.3443,-1.16323
16-12-2019 11:41:0 51.3442,-1.16198
16-12-2019 11:41:5 51.3455,-1.15886
16-12-2019 11:41:10 51.3473,-1.15654
16-12-2019 11:41:30 51.3471,-1.1554
16-12-2019 11:41:35 51.3473,-1.15255
16-12-2019 11:41:40 51.346,-1.14843
16-12-2019 11:41:45 51.3492,-1.1376
16-12-2019 11:41:50 51.3487,-1.1365
16-12-2019 11:41:55 51.3486,-1.13539
16-12-2019 11:42:0 51.3495,-1.1369
16-12-2019 11:42:5 51.3595,-1.14676
16-12-2019 11:42:10 51.3605,-1.16162
#break
```

 **Note:** Additional comments could be added to either of the files. Comments should be added before the header of the file (“Data Time Lat, Lon...”) and should start with #.

9.3.4.2. Save As

Modifications of the data made via any of the methods previously described will not be automatically saved. To save any changes, navigate to the menu bar and click **File** → **Save As** or press Ctrl + S.



Note: Always make sure that the name of either of the data type files starts with a date in *dd-mm-yyyy* format.

9.3.4.3. Load

To load a data file, navigate to the menu bar and click **File** → **Open** or press Ctrl + O. Only files with .log and .btr extension can be loaded.

All the data from a .log file will be loaded and visualised except for the Aquarius location, if present.

It is possible to load both .log and .btr at the same time. To do so, simply select them together when loading the files. The only condition is that the two files are from the same deployment, i.e. the date in the name of the files is the same.

9.4. Aquarius Recovery

Use the *Recovery* tab of the **OBS Command and Control** tool to activate the release of the ballast (Section 9.1.6). Once the Aquarius reaches the sea surface, the recovery aids will be automatically activated by the pressure sensor.

Once the Aquarius has been recovered, it must be connected to the deck unit using the *Aquarius Ethernet* connector. Power over Ethernet (PoE) must then be enabled to power up the LPC in normal operating mode. In this state, the LPC establishes a PTP time lock, while the ULPD remains in the deployed (free-running) state. This configuration allows the time offset between the LPC and the ULPD to be determined during recovery.

The **Aquarius Recovery** tool guides the user through the process following instrument retrieval.

Aquarius Ocean Bottom System

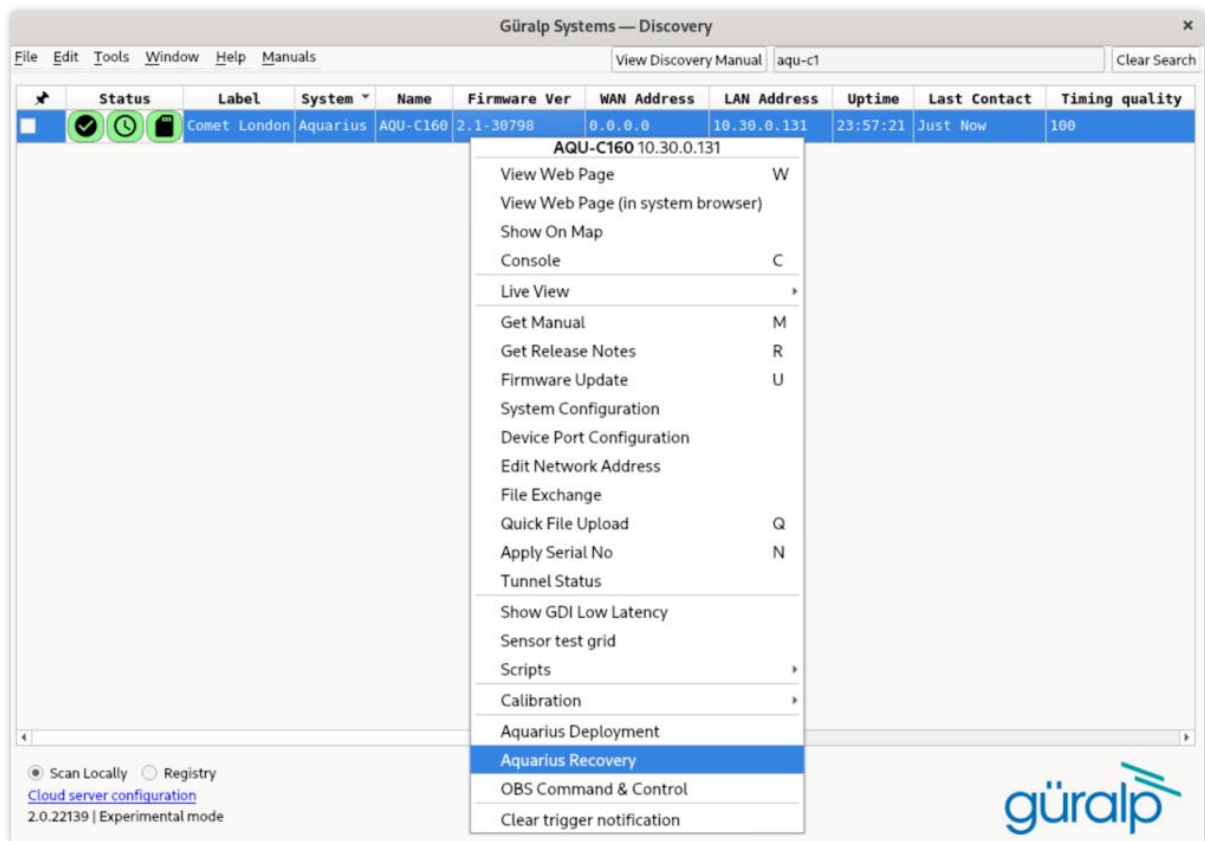

At the top of the window, the instrument identifier and current deployment status are displayed.

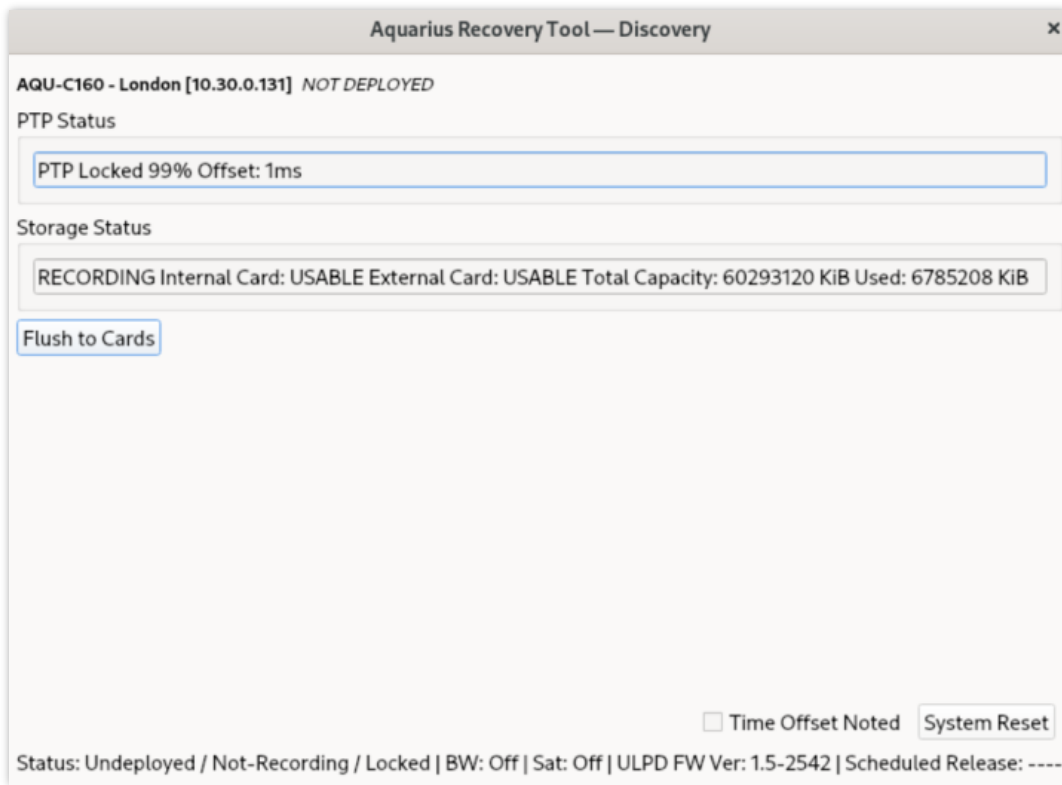

The **PTP Status** field indicates the current time synchronisation state of the LPC. A status such as “*PTP Locked 99% Offset: 1 ms*” indicates that the LPC has successfully synchronised to the PTP time server. The reported offset represents the time difference between the LPC and ULPD.

During recovery, once PTP stability approaches 100%, the time offset between the LPC and the ULPD should be noted. The **Time Offset Noted** checkbox is used to confirm that this step has been completed.

The **Storage Status** section reports the current recording state and the availability of the internal and external storage cards, including total capacity and used space. The **Flush to Cards** button allows any buffered data to be written to the storage media before proceeding.

After the time offset has been recorded and a data flush has been completed, click on the **System Reset** button.



Note: Performing a system reset from the *Aquarius Recovery* tool alone is not sufficient to fully undeploy the Aquarius. To return the system to the **Undeployed** state, a second system reset must be performed from the webpage (as described in Section 8.11).

If the second reset is not performed, the Aquarius will revert to the **Deployed** state after a short period of time. This is a deliberate safeguard to prevent accidental undeployment.

9.5. Remote Deck Unit

The Discovery instance running on a Deck Unit can be used by other Discovery instances on the network to control an Aquarius and communicate with the acoustic modem remotely. This is useful if you want the Deck Unit and modem left on the deck of the boat while you use a Discovery from inside somewhere more comfortable. More information can be found in [Discovery manual](#).

10. Download Recorded Data

The **Storage** tab of the web browser interface displays the miniSEED files stored on the microSD card:

The screenshot shows the Aquarius web interface. At the top right, there is a logo for 'güralp' and the text 'UNDERSTAND OPTIMISE PROTECT'. Below the logo is the name 'Aquarius'. A navigation menu contains: Status, Network, Setup, Power, Trigger, Data Stream, Data Record, Transforms, **Storage**, Logout, Help. Below the menu, system information is displayed: 'System type: Aquarius | Host label: DIAS-AQUARIUS | Host name: AQU-00205A (10.30.0.73) | Serial number: 00205A'. The main content area is titled 'SD Card control' and contains three buttons: 'Unmount Cards', 'Quickformat Cards', and 'Fullformat Cards', along with the text 'Formatting status: idle'. Below this is the 'SD Cards status' section, which is a table with the following data:

External microSD card present	PRESENT	Number of 128-MiB miniSEED files	463
External microSD card usable	USABLE	Internal microSD card usable	USABLE
External microSD card init count	1	Internal microSD card init count	1
External microSD card is primary microSD card	PRIMARY	Internal microSD card is primary microSD card	BACKUP
Primary microSD card is recording samples	RECORDING	Backup microSD card is recording samples	RECORDING

Below the status table is the 'SD Card files' section, which is a table listing files. The table has columns for 'Filename', 'Size (bytes)', and 'Last data timestamp'. The files listed are:

Filename	Size (bytes)	Last data timestamp
00C95A_S1SeisEFR_00250_00000.mseed	18337792	2019-09-11 07:16:58.000000000
00C95A_S1SeisXFR_00100_00001.mseed	3272704	2019-09-11 07:16:58.000000000
00C95A_S1PresFR_00005_00002.mseed	483328	2019-09-11 07:16:58.000000000
00205A_S0TempRA_00010_00003.mseed	454656	2019-09-11 11:26:05.700000000
00205A_S0HumidA_00010_00004.mseed	450560	2019-09-11 11:26:30.200000000
00205A_S0Voltage_00010_00005.mseed	491520	2019-09-11 11:27:22.300000000
00C95A_S1TempSeaFR_00001_00006.mseed	204800	2019-09-11 07:16:58.000000000
00C95A_S1PowerFR_00001_00007.mseed	204800	2019-09-11 07:16:58.000000000
00C95A_S1RatioZFR_00001_00008.mseed	225280	2019-09-11 07:16:58.000000000
00C95A_S1LTAZFR_00001_00009.mseed	204800	2019-09-11 07:16:58.000000000
00C95A_S1STAZFR_00001_00010.mseed	204800	2019-09-11 07:16:58.000000000
00C95A_S1IntEFR_00005_00011.mseed	319488	2019-09-11 07:16:58.000000000
00C95A_S1IntNFR_00005_00012.mseed	299008	2019-09-11 07:16:58.000000000
00C95A_S1IntZFR_00005_00013.mseed	356352	2019-09-11 07:16:58.000000000
00C95A_S1ExtPresFR_00005_00014.mseed	331776	2019-09-11 07:16:58.000000000
00C95A_S1APGFR_00005_00015.mseed	339968	2019-09-11 07:16:58.000000000
00C95A_S1VoltageFR_00005_00016.mseed	356352	2019-09-11 07:16:58.000000000
00C95A_S1HumidBFR_00005_00017.mseed	368640	2019-09-11 07:16:58.000000000
00C95A_S1TempBFR_00005_00018.mseed	356352	2019-09-11 07:16:58.000000000
00205A_S0SeisXFR_00100_00019.mseed	3235840	2019-09-11 07:16:58.000000000

Clicking on the file from the list automatically starts a download using your browser's standard mechanism:

Aquarius Ocean Bottom System

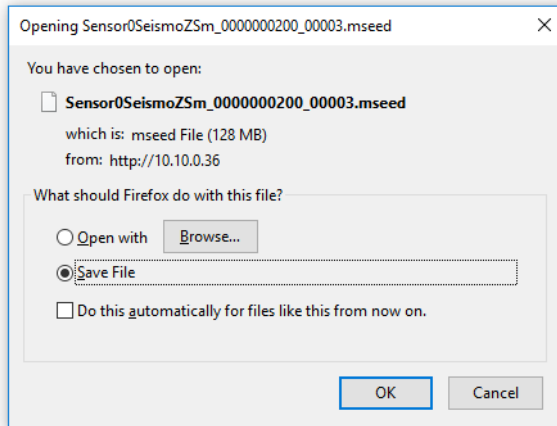

Multiple files can be downloaded simultaneously by ticking the boxes on the left of each link and clicking on **Download selected files** button.

Data for a single stream spanning a specific time-interval can be downloaded from the Storage page of the web interface. To do this, start by selecting the desired stream from the drop-down menu:

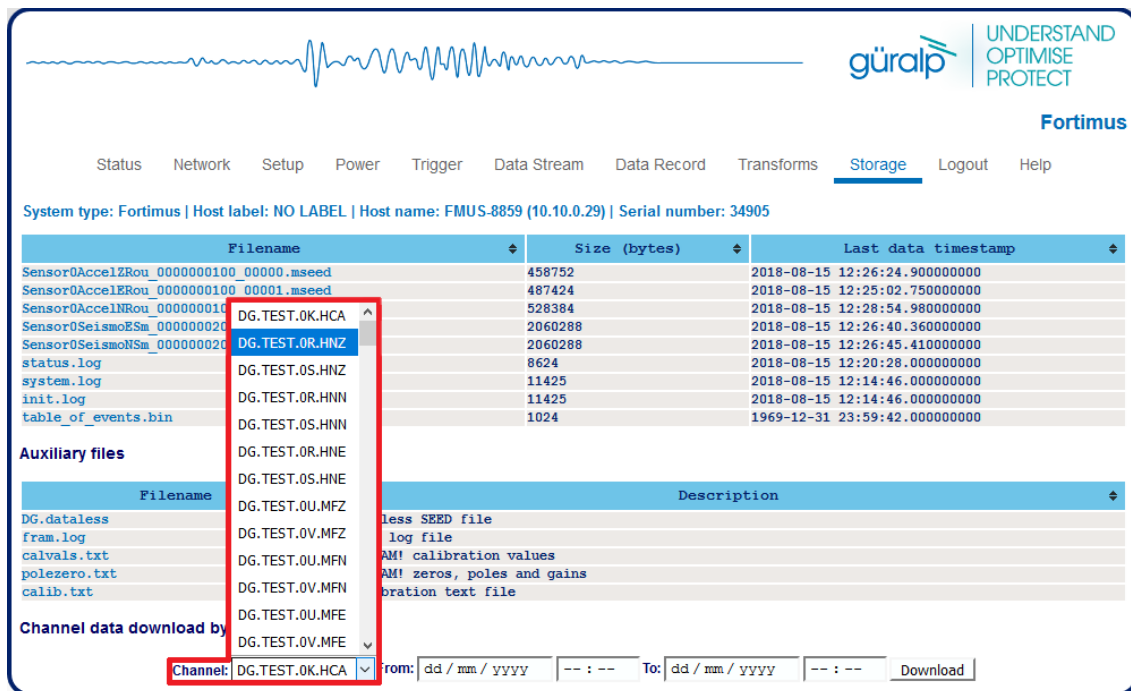

then select the start and end dates and times using the pop-up calendars:

Aquarius Ocean Bottom System

The screenshot shows a web interface with a calendar pop-up for August 2018. The calendar is centered on August 15th. Below the calendar, there is a 'Channel data download by time selection' section with a 'Channel' dropdown set to 'DG.TEST.OK.HCA', a 'From' date field set to 'dd/mm/yyyy', and a 'Download' button.

Lastly, click the **Download** button to initiate a file transfer using your browser's standard mechanism.

 **Note:** The pop-up calendars are not supported by Discovery's built-in browser and Explorer. The required dates can simply be typed in or the entire operation can be performed in an external web browser.

The **Storage** tab also shows links to five auxiliary files, which are either saved in the Aquarius flash RAM, in the microSD card or are dynamically generated:

The root directory of the SD card contains:

- a file named `init.log`. This contains the first 32 MiB of system log information since the card was last formatted;
- a file named `system.log`. This contains the last 64 MiB of the system log'
- a file named `status.log`. This contains the last 32 MiB of dumps of system state of health information. A new dump is generated every 20 minutes.
- a file named `table_of_events.bin`. This is not human readable: it is used by the Seismic Events Table in the "Trigger" tab

<input type="checkbox"/>	<code>status.log</code>	42205	2019-09-11 11:13:19.000000000
<input type="checkbox"/>	<code>system.log</code>	45406	2019-09-11 11:32:05.000000000
<input type="checkbox"/>	<code>init.log</code>	45311	2019-09-11 11:32:05.000000000
<input type="checkbox"/>	<code>table_of_events.bin</code>	39936	2019-09-11 06:54:55.000000000

The remaining files are listed in the Auxiliary files section:

- `network_station.dataless`: where *network* is the Network code and *Station* the station code, as defined in the **Setup** tab (e.g. DG_TADL.dataless). This file is a dataless SEED volume that contains metadata including instrument responses, coordinates, compression type etc. The dataless SEED volume is generated from the .RESP files for each channel;
- `fram.log`: FRAM log file (stored in FRAM);
- `calvals.txt`: calibration values in the format compatible with the Scream! Software package (dynamically generated);

Aquarius Ocean Bottom System

- `polezero.txt`: poles, zeros and normalising factors in the format compatible with the Scream! software (dynamically generated);
- `calib.txt`: calibration text file with poles, zeros and gains expressed in hexadecimal (stored in FRAM);

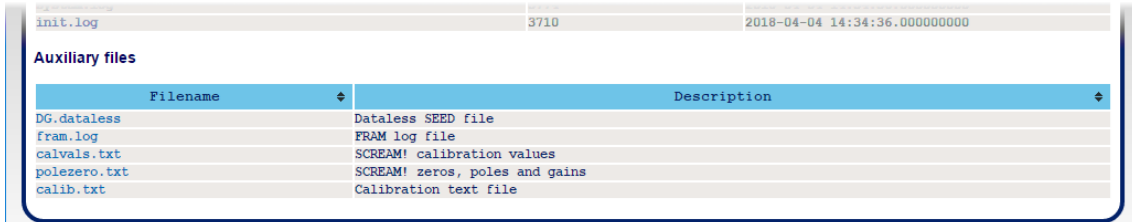

The screenshot shows a file manager window with a header bar containing 'init.log', '3710', and '2018-04-04 14:34:36.000000000'. Below the header is a section titled 'Auxiliary files' containing a table with two columns: 'Filename' and 'Description'. The table lists the following files:

Filename	Description
DG.dataless	Dataless SEED file
fram.log	FRAM log file
calvals.txt	SCREAM! calibration values
polezero.txt	SCREAM! zeros, poles and gains
calib.txt	Calibration text file

10.1.1. Bulk Data Extraction via Network

Files stored on the SD card can be downloaded using HTTP. The example bash script below can be used from a Linux PC or from the WSL shell on a Windows PC: it extracts all files from the SD Card into a directory named after the date and the network address of the instrument.

```
#!/bin/bash
# Invoke with one argument: the network
# address of the instrument
set -x

if [ "$#" -ne 1 ] ; then
    echo "Usage: $(basename $0) network_address"
    exit 1
fi

NET_ADDRESS=$1
DATE=$(date --iso-8601)
SAVEDIR = ${DATE}_${NET_ADDRESS}
echo Saving to $SAVEDIR

mkdir $SAVEDIR
cd $SAVEDIR
wget -rnp http://$NET_ADDRESS/tab9.html
cd ..

echo Done
```

10.1.2. Time Based Data Extraction via Network

The example Python script below will extract seismic data from the SD card based on a specified time interval. This is similar to the FDSN data archive retrieval service: <https://www.fdsn.org/webservices/fdsnws-dataselect-1.1.pdf>

Aquarius Ocean Bottom System

Channel names are as given on the "Recording" tab of the web interface and the times are specified as UNIX Epoch seconds since 1970 (UTC). The resulting file is in miniSEED format.

The script forms an http request to the instrument in the form

`http://192.168.254.101/data?channel=DG.TEST.01.CHZ&from=1605810714&to=1605810814`

```
import os
import wget
from obspy import read, read_inventory, UTCDateTime
from obspy.signal import PPSD

##### Start of variable to set #####
temp = os.environ["TEMP"]
sensor = "192.168.254.101"
channel = "DG.TEST.01.HHZ"
start = UTCDateTime("2020-10-19T00:00:00.0")
end = UTCDateTime("2020-10-19T06:00:00.0")
##### End of variables to set #####

startUNIX = UTCDateTime(start).timestamp
#We use the 'start'&'end' to cut the data using Obspy
endUNIX = UTCDateTime(end).timestamp
# We use the 'startUNIX'&'endUNIX' to pull the
# data from the instrument

if os.path.exists(r"{0}\tt.mseed".format(temp)):
# See if temp file exists, if so delete.
    os.remove(r"{0}\tt.mseed".format(temp))

print(r"http://{0}/data?channel={1}&from={2}&to={3}".format(sensor,
channel, startUNIX, endUNIX))
wget.download(r"http://{0}/data?channel={1}&from={2}&to={3}".format(sensor,
channel, startUNIX, endUNIX),
r"{0}\tt.mseed".format(temp))

st = read(r'{0}\tt.mseed'.format(temp), starttime=start,
endtime=end, format='MSEED')
print(st)
st.plot()
dataless =
read_inventory(r'http://{0}/DG.dataless'.format(sensor))

ppsd = PPSD(st[0].stats, metadata=dataless)
ppsd.add(st)
ppsd.plot()
```

The following example in bash allows you to extract from the SD card the three seismic components at a given date and time, and specify the length of the miniSEED files. It then combines the three component in an individual miniSEED file, which name includes the network code, station code, start date and time :

Aquarius Ocean Bottom System

```
#!/bin/bash
# Invoke with one argument: the IP address

set -x

# enter your network details
net_code=DG
station_code=04D67
location_code=0L

# choose the day
day=2024-04-28

# choose the start time in 24-hours format (e.g. 16 = 4pm)
start_hour=16

# choose the length of the miniSEED in hours (e.g. 1 = 1-hour-
long miniSEED)
step=1

utc=$(date --date ${day} +%s)
start_utc=$(expr $utc + 3600 \* ${start_hour})
end_utc=$(expr ${start_utc} + 3600 \* ${step})

echo $utc
echo $start_utc
echo $end_utc

wget -v -Oz_component.mseed
http://$1/data?channel=${net_code}.${station_code}.${location_code}
.HNZ\&from=${start_utc}\&to=${end_utc}
wget -v -On_component.mseed
http://$1/data?channel=${net_code}.${station_code}.${location_code}
.HNN\&from=${start_utc}\&to=${end_utc}
wget -v -Oe_component.mseed
http://$1/data?channel=${net_code}.${station_code}.${location_code}
.HNE\&from=${start_utc}\&to=${end_utc}

# Convert from Unix timestamp to date and time
date_string=`date -d @$start_utc +%Y.%m.%d-%H.%M.%S`

# In this example, the 3-components miniSEED file will be named
"DG.04D67-2024.04.28-16.00.00.mseed"
cat z_component.mseed n_component.mseed e_component.mseed >
${net_code}.${station_code}-${date_string}.mseed
```

10.1.3. Metadata

The Aquarius provides several forms of metadata describing the station details, sensitivity, and response of all channels. Metadata is essential for understanding and correctly

interpreting recorded data. It defines how the digitiser converts analogue motion into digital counts, and how each channel responds across frequency.

The device automatically generates three metadata formats: RESP files, Station XML files, and a Dataless SEED volume. Each format serves a different purpose, ranging from per-channel response information to complete system-wide metadata. The following sections describe each type and explain how to download them.

10.1.3.1. RESPonse Files

RESP files contain channel-specific response information. Each RESP file describes a single sensor channel. This includes the overall sensitivity, gain and filter stages, poles and zeros, and instrument identifiers. They are human-readable text files commonly used by analysis tools such as ObsPy, SAC, and PDCC.

Accessing RESP files:

Each channel's RESP file is available from the **Data Stream** and **Data Record** pages via the RESP file link:

System type: Minimus | Host label: SPRT-MIN | Host name: MIN-C555 (10.10.0.10) | Serial number: 00C555

Channel sampling rate	Data transform	SEED name - please use check-box to modify the default	RESPonse file - if available
Seismic channels			
0AUXX0	200 Hz	Transforms Disabled for this tap	RESP_file_5
0VELZ0	200 Hz	Transforms Disabled for this tap	RESP_file_7
0VELN0	200 Hz	Transforms Disabled for this tap	RESP_file_11
0VELE0	200 Hz	Transforms Disabled for this tap	RESP_file_15

Clicking the link opens the RESP information in your browser:

Aquarius Ocean Bottom System

```
#          << Guralp SEED response file builder v1.2-8615 >>
#
#          ===== CHANNEL RESPONSE DATA =====
B050F03   Station:      TEST
B050F16   Network:     DG
B052F03   Location:    OK
B052F04   Channel:     HNZ
B052F22   Start date:  2018,214,11:26:48
B052F23   End date:    No Ending Time
#
#          +-----+-----+-----+
#          +-----+-----+-----+
#          +-----+-----+-----+
#          +-----+-----+-----+
#
B058F03   Stage sequence number:      0
B058F04   Sensitivity:                2.131148E+05
B058F05   Frequency of sensitivity:   1.000000E+00 HZ
B058F06   Number of calibrations:     0
#
#          +-----+-----+-----+
#          +-----+-----+-----+
#          +-----+-----+-----+
#          +-----+-----+-----+
#
B053F03   Transfer function type:     A [Laplace Transform (Rad/sec)]
B053F04   Stage sequence number:     1
B053F05   Response in units lookup:  M/S**2 - Acceleration in Metres Per Second Squared
B053F06   Response out units lookup:   V - Volts
B053F07   A0 normalization factor:    3.022955E+12
B053F08   Normalization frequency:    1.000000E+00
```

To download the file, right-click the link and select **Save Link As:**

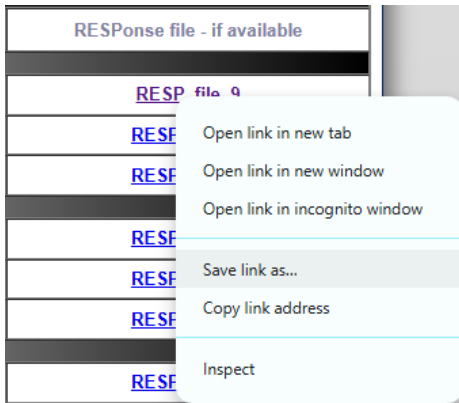

RESP files can also be accessed by URL, for example:

http://<device-ip>/RESP_file_<n>.txt

Example using wget from a command line:

```
wget http://10.20.1.87/RESP_file_7.txt
```

10.1.3.2. Station XML Files

Station XML is a modern format widely used for exchanging seismic metadata. It contains structured metadata for an entire sensor, including all channel responses, sensor orientation and location, calibration constants, digitiser sensitivity, and station identifiers.

Accessing Station XML files:

Station XML files are available from the **Storage** page as Sensor0.xml and Sensor1.xml. Specifically, seismic channels' metadata are contained in Sensor1.xml To download a file, tick the checkbox next to it and click **Download selected files:**

Aquarius Ocean Bottom System

<input type="checkbox"/>	status.log	11869910	2024-09-05 09:23:05.000000000
<input type="checkbox"/>	system.log	33825052	2024-09-05 09:28:19.000000000
<input type="checkbox"/>	init.log	33554432	2024-08-31 07:05:58.000000000
<input checked="" type="checkbox"/>	Sensor0.xml	1354917	2024-09-04 16:29:10.000000000
<input type="checkbox"/>	Sensor1.xml	555723	2024-09-04 16:29:16.000000000
<input type="checkbox"/>	data.xml	34059	2024-08-28 15:58:29.000000000
<input type="checkbox"/>	table_of_events.bin	7168	2024-09-03 15:54:38.000000000

Download selected files

They can also be accessed via direct URL, for example:

<http://<device-ip>/sd/Sensor<n>.xml>

Using wget from the command line:

```
wget http://10.20.1.87/sd/Sensor1.xml
```

10.1.3.3. Dataless SEED Volume

A Dataless SEED Volume contains all metadata for the digitiser and every connected sensor, including response stages, sensitivities, channel naming, and network/station codes. It does not contain waveform data; instead, it complements MiniSEED files by providing the metadata needed to interpret them.

Accessing dataless SEED Volume:

The dataless volume is available from the **Storage** page under Auxiliary Files. Clicking the filename will download it directly to your computer:

Auxiliary files	
Filename	Description
DG_QA555.dataless	Dataless SEED file
fram.log	FRAM log file
Certis.xml	Certis StationXML
calvals.txt	SCREAM! calibration values
polezero.txt	SCREAM! zeros, poles and gains
calib.txt	Calibration text file
seedlink.log	Seedlink server log

As with RESP and StationXML file, it can also be retrieved by URL. The filename is formed from the two-character network code and the station code. For example, if the network code is DG and the station code is TADL, the dataless filename is:

DG_TADL.dataless

An example direct URL would be:

http://<device-ip>/<net_code>_<stat_code>.dataless

You may also download it using wget:

```
wget http://10.20.1.87/DG_TADL.dataless
```

11. Appendix A – Channel Names

11.1. Data Streaming

The table in this section shows the names and codes of the streamed channels. The first character “x” in miniSEED channel code represents the sample rate. The possible values are shown in the table below:

F	≥ 1000 Hz to < 5000 Hz
C	≥ 250 Hz to < 1000 Hz
H	≥ 80 Hz to < 250 Hz
B	≥ 10 Hz to < 80 Hz
M	> 1 Hz to < 10 Hz
L	≈ 1 Hz
V	≈ 0.1 Hz
U	≈ 0.01 Hz
R	≥ 0.0001 Hz to < 0.001 Hz

Sensor	Component	Digital filter mode	Data streaming		
			Live stream name	Live Stream code	miniSEED channel code
Seismometer (velocity response)	Vertical	Acausal	S1SeisZ	1VELZ0	xHZ
			S1SeisZ	1VELZ2	xHZ
		Causal	S1SeisZLowLat	1VELZC	xHZ
	North	Acausal	S1SeisN	1VELN0	xHN
			S1SeisN	1VELN2	xHN
		Causal	S1SeisNLowLat	1VELNC	xHN
	East	Acausal	S1SeisE	1VELE0	xHE
			S1SeisE	1VELE2	xHE
		Causal	S1SeisELowLat	1VELEC	xHE
Digital seismic sensor mass position	Vertical	Acausal	S1IntZ	1INTZ0	xMZ
	North	Acausal	S1IntN	1INTN0	xMN
	East	Acausal	S1IntE	1INTE0	xME
MEMS accelerometer	Vertical	Acausal	S1AccZ	1AXLZ0	xNZ
		Causal	S1AccZLowLat	1AXLZC	xNZ
	North	Acausal	S1AccN	1AXLN0	xNN
		Causal	S1AccNLowLat	1AXLNC	xNN
	East	Acausal	S1AccE	1AXLE0	xNE

Aquarius Ocean Bottom System

Sensor	Component	Data streaming			
		Digital filter mode	Live stream name	Live Stream code	miniSEED channel code
		Causal	S1AccELowLat	1AXLEC	xNE
Magnetometer	Z	Acausal	S1MagZ	1MAGZ0	xFZ
	N	Acausal	S1MagN	1MAGN0	xFN
	E	Acausal	S1MagE	1MAGE0	xFE
	Yaw	Acausal	S1RotYaw	1ROTY0	xYY
	Pitch	Acausal	S1RotPitch	1ROTP0	xYP
	Roll	Acausal	S1RotRoll	1ROTR0	xYR
Temperature	Sea temperature chain	Acausal	S1TemprSea	1TSEA0	xKO
	Sensor temperature	Acausal	S1TemprB	1TMPB0	xKO
Humidity within sensor enclosure		Acausal	S1HumidB	1HUMB0	xIO
Pressure	Within sensor enclosure	Acausal	S1Pressure	1PRSR0	xDI
	External sea	Acausal	S1ExtPressure	1PRSR1	xDO
	ParoScientific	Acausal	S1APG	1PRSR2	xDU
PLL clock offset		Acausal	S1PLLOffset	1PLL0	xYO
Sensor power		Acausal	S1Power	1PWR0	xE0
Sensor input voltage		Acausal	S1Voltage	1VOLT0	xE1
STA/LTA	STA	Acausal	S1STAZ	1STAZ0	xZ0
	LTA	Acausal	S1LTAZ	1LTAZ0	xZ1
	Ratio	Acausal	S1RatioZ	1RatZ0	xZ2

11.2. Data Recording

Sensor	Component	Data recording		
		Digital filter mode	Data Record name	miniSEED channel code
Seismometer (velocity response)	Vertical	Acausal	S1SeisZFR	CHZ
	North	Acausal	S1SeisNZFR	CHN
	East	Acausal	S1SeisEFR	CHE
	Vertical	Acausal	S1IntZFR	MMZ
	North	Acausal	S1IntNFR	MMN

Aquarius Ocean Bottom System

Sensor	Component	Data recording		
		Digital filter mode	Data Record name	miniSEED channel code
Digital seismic sensor mass position	East	Acausal	S1IntEFR	MME
Temperature	Sea temperature chain	Acausal	S1TemprSeaFR	LKO
	Sensor temperature	Acausal	S1TemprBFR	MKO
Humidity within sensor enclosure		Acausal	S1HumidBFR	MIO
Pressure	Within sensor enclosure	Acausal	S1PresFR	MDI
	External sea	Acausal	S1ExtPresFR	MDO
	ParoScientific	Acausal	S1APGFR	MDU
PLL clock offset		Acausal	S1PLLOffsetFR	MYO
Sensor power		Acausal	S1PowerFR	LE3
Sensor input voltage		Acausal	S1VoltageFR	ME4
STA/LTA	STA	Acausal	S1STAZFR	LZ0
	LTA	Acausal	S1LTAZFR	LZ1
	Ratio	Acausal	S1RatioZFR	LZ2

12. Appendix B – Connector Pin-Outs

12.1. OBS – APG/Hydrophone and Burn-Wire

This is a SubConn Micro Circular 8-way socket connector.



Pin	Function
1	Burn-Wire DC+
2	Burn-Wire DC-
3	APG FRQ Temperature
4	APG FRQ Pressure
5	APG RS-232 Tx / Hydrophone Signal +
6	APG RS-232 Rx / Hydrophone Signal -
7	APG RS-232 Gnd / Hydrophone Gnd
8	APG V+ / Hydrophone Power



Wiring details for the compatible plug, as seen from the cable end (*i.e.* when assembling).

12.2. OBS – Ethernet and Serial RS-232

This is a SubConn 13-way Power Data Circular socket connector.



Pin	Function
1	Ethernet C+
2	Ethernet C-
3	Ethernet D+
4	Ethernet D-
5	Ethernet A+
6	Ethernet A-
7	Ethernet B+
8	Ethernet B-
9	LPC RS-232 Tx
10	ULPD RS-232 Tx
11	ULPD RS-232 Rx
12	LPC RS-232 Rx
13	ULPD Ground

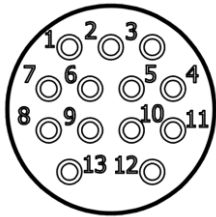

Wiring details for the compatible socket, as seen from the cable end (*i.e.* when assembling).

12.3. OBS – Battery Charger

These are standard 32-way military-specification bayonet plug.



Pin	Function	Pin	Function	Pin	Function
A	P1 T4 charge (pack 1 4S main + connection)	M	P0 T4 charge (pack 0 4S main +connection)	Z	P0 T1 sense link connection (pack 0 1S+)

Aquarius Ocean Bottom System

B	P1 T4 charge (pack 1 4S main + connection)	N	P0 T4 charge (pack 0 4S main +connection)	a	P0 T2 sense link connection (pack 0 2S+)
C	Temperature sense positive	P	P2 T2 sense link connection (pack 2 1S+)	b	P0 T4 sense link connection (pack 0 4S+)
D	P2 T0 charge (pack 2 1S main - connection)	R	P1 T0 charge (pack 1 1S main - connection)	c	P0 T0 sense link connection (pack 0 1S-)
E	P2 T0 charge (pack 2 1S main - connection)	S	P1 T0 charge (pack 1 1S main - connection)	d	P2 T1 sense link connection (pack 2 1S+)
F	P2 T0 sense line connection (pack2 1S-)	T	P1 T2 sense link connection (pack 1 1S+)	e	P1 T1 sense link connection (pack 1 1S+)
G	P2 T4 charge (pack 2 4S main + connection)	U	P1 T4 sense link connection (pack 1 4S+)	f	P1 T3 sense link connection (pack 1 3S+)
H	P2 T4 charge (pack 2 4S main + connection)	V	P1 T0 sense link connection (pack 1 1S-)	g	P2 T3 sense link connection (pack 2 3S+)
J	P0 T0 charge (pack 0 1S main - connection)	W	Temperature sense negative	h	24 V DC charge enable +
K	P0 T0 charge (pack 0 1S main - connection)	X	Temperature sense signal	j	24 V DC charge enable -
L	P0 T3 sense link connection (pack 0 3S+)	Y	P2 T4 sense link connection (pack 2 4S+)		



Wiring details for the compatible socket, as seen from the cable end (*i.e.* when assembling).

13. Appendix C – Acoustic Modem Link

13.1. Description of Operation

The acoustic data transmission link between an Aquarius and the surface comprises of two nodes; referred to here as a *Surface* (Ship based Deck Unit or Buoy System) and *Bottom* (Aquarius or Aquarius) modems. The *Bottom* modem type and capability varies between Aquarius and Aquarius, but the principles of operation and fault finding are the same.

Each modem, *Surface* or *Bottom*, has a unique identification number which is set at the factory; this is rarely used directly. Acoustic modems have a more convenient user configurable *Acoustic Modem Address* which is used to direct communications to correct nodes.



Caution: It is essential to know the *Acoustic Modem Address* of the modem you wish to communicate with. **Be sure to note the address of an Aquarius before deployment.**

Each communication node has the concept of *Local* and *Remote*. The *Local Acoustic Modem Address* is the address of the modem at node you are directly interacting with; the *Remote Acoustic Modem Address* is the address of the modem you wish to communicate with acoustically.

There are two types of acoustic transmission: *Commands* and *Data*. *Commands* are modem-only communications pertaining to the operation, configuration and status of the acoustic modems themselves. The system (*e.g.* Aquarius, buoy system or deck unit) attached to a modem that has a *Command* directed at it is not aware that an acoustic transmission has taken place (and will not wake up if asleep, for example).

Data transmissions are acoustic transmissions that require interaction with, or a response from, the attached *Surface* or *Bottom* systems. Setting a time for the backup burn wire operation, commanding an OBS to perform re-centring, obtaining seismic data from an OBS and an OBS informing a *Surface* system of a seismic event are all examples of acoustic *Data* transmissions.

Commands are shorter and more robust acoustic transmissions than *Data* transmissions. Therefore, it is good practice to make first contact with a deployed OBS with a *Command* to verify the quality of an acoustic link.

Data transmissions (sent with the *MDFT* command) are typically much longer than *Commands*. Each *Data* transmission frame is split up into multiple sub-frame transmissions, up to 16 per frame. The number of sub-frames required to send a given packet of data depends on the bit rate. Data packets to be transferred between *Surface* and *Bottom* nodes are always sized to fit within one acoustic transfer frame, regardless of bit rate. Larger transmissions are split into smaller packets to ensure this.

13.1.1. Modem Configuration

This manual is not intended to serve as a reference for the acoustic modem protocol; a subset of possible configuration options and parameters is included, limited to those which are most likely to require alteration during the operation of the Aquarius and associated systems.

These parameters fall into three categories; *Power & Gain*, *Delay* and *Bit rate & Retries*.

13.1.1.1. Power & Gain

In order for two acoustic modem nodes to communicate, the strength of the acoustic signals they transmit and the sensitivity to incoming signals being received must be appropriate for the parameters of the installation.

Power

There are two relevant configuration parameters for setting power levels of acoustic transmission in a modem: *Start Power Level (SPL)* and *Telemetry Power Level (TPL)*. These must be set at an appropriate level for the particular depth of water. It is important to note that more power does not always result in a stronger acoustic link, especially in shallow water scenarios. Higher transmission power increases the likelihood of destructive acoustic reflections and saturation at the receiving node. Instead, a sufficient power level should be chosen.

The selection of power parameters should be performed using the *OBS Command & Control* window for the *Surface* modem, and the *Bottom* modem if the OBS has already been deployed. The *Acoustic Configuration* tab contains controls for setting power, gain and other parameters dependant on depth under *Depth Configuration* (see Section 9.1.2).

The depth related power and gain settings should be set *Locally* in the *Bottom* OBS node before deployment via the LPC web interface, **Network** tab (see Section 7.2.6).

It is also possible to read and set these parameters manually using the *Configuration Status (CS)* command (see Section 13.2). This should only be attempted with support from Güralp.

Gain

In addition, it is possible to set the gain of acoustic signals as they are received at a modem. This is known as the Linear Gain (LG) parameter. It is desirable to set LG as low as possible yet as high as necessary. Too high a gain setting will result in saturation and increased noise (lower signal to noise ratio). Too low a gain will result in a weak acoustic link and, in the worst case, loosing communication with an OBS Bottom node altogether.



Caution: While most acoustic parameters can be corrected if incorrectly set, setting *Linear Gain (LG)* too low for a given depth may result in **permanently** loosing communications with a deployed OBS. Exercise special caution when setting or changing LG.

The selection of *LG* should be performed using the Discovery *OBS Command & Control* window for the *Surface* modem, and the *Bottom* modem if the OBS has already been deployed. The *Acoustic Configuration* tab contains controls for setting power, gain and

other parameters dependant on depth under *Depth Configuration* (see Section 7.1.3.3 on page 55).

The depth related power and gain settings should be set *Locally* in the *Bottom* OBS node before deployment via LPC web interface. This is especially important for *LG, Network* tab (see Section 7.2.6).

It is also possible to read and set these parameters manually using the *Configuration Status (CS)* command (see Section 15.2). This should only be attempted with support from Güralp.

13.1.1.2. Delays

Receiver Wait

The primary delay parameter, that has the most impact on the success of acoustic transmissions, is *Receiver Wait* or *RXW*. *RXW* defines the amount of time an acoustic modem will wait for a response from the receiving node for.

The correct delay setting depends exclusively on the distance between two communicating acoustic modems (slant range). This is dictated by the installation depth of the OBS, apart from situations which require a large ratio of lateral distance to depth (these should be avoided as much as possible).

The depth related *RXW*, along with *NPL*, *TPL* and *SPL*, should be set *Locally* in the *Bottom* OBS node before deployment via LPC web interface, "Network" tab (see Section 7.2.6).

In the surface modem *RXW* should be set, along with *NPL*, *TPL* and *SPL*, in the depth configuration section of the *Acoustic Configuration* tab of the *Discovery Command & Control* window (see Section 7.1.3.3 on page 55). Using the same tab of the *OBS Command & Control* widget it is also possible to change *RXW* in the bottom modem via acoustic command.

Local Modem Delays

Local modem delays define the timings of the interactions between a modem and the attached system (*Surface* or *Bottom/OBS*). These delays only impact *Data* transmissions with the *MDFT* command. None of the local modem delays should require alteration during the deployment, operation or recovery of an Aquarius. Changing these parameters should only be attempted with guidance from Güralp.

Data Delay or *DD* defines the time delay between the end of one sub-frame transmission and the beginning of the next.

Modem Delay or *MD* defines the maximum time that the recipient modem of a request for data will wait before sending a reply. This allows the attached system to provide data to the modem for the response. It takes effect when the responding modem does not already have data to send.

Uplink Delay or *UD* defines the time that the recipient modem of a request for data will wait before sending a reply in the case of data having already been loaded for the response.

Inter Character Time or *ICT* is the timeout implemented by the recipient modem of a request for data before automatically sending the response. It is applied after the first character is sent serially from the associated system.

All of the local modem delays for the *Surface* and *Bottom* modems can be read and set via the *Modem Delays* section of the *Acoustic Configuration* tab in the *OBS Command & Control* window in Discovery.

It is also possible to read and set these parameters manually using the *Modem Status (MS)* command (see Section 15.2). This should only be attempted with support from Güralp.

13.1.1.3. Bitrate & Retries

Bitrate

For *Data* transmissions it is possible to define the bitrate (*TS*) that data sub-frames will be transmitted at. Higher bitrates allow a given packet of data to be transferred faster and with fewer sub-frames, but in certain conditions it increases the risk of the recipient modem not successfully receiving the sub-frame and discarding it.

 **Note:** The setting of bitrate does not affect *Commands*.

The *Data* transmission bitrate should be set in via the *Acoustic Baud Rate* section in the *Acoustic Configuration* tab of the *OBS Command & Control* window (see Section 7.1.3.3 on page 56). The optimal bitrate setting is the highest value that only infrequently causes lost sub-frames.

 **Caution:** Decreasing the bitrate in the OBS modem, when it is not needed, wastes energy. The user should always aim to the highest bit rate possible to optimize the energy per bit during acoustic data transfer.

It is also possible to set the bitrate manually by changing the *Telemetry Scheme* or *TS* parameter using the *MS* command (see Section 15.2).

 **Note:** It is possible, and sometimes desirable, to set different bitrates (*TS*) in the *Surface* and *Bottom* modems, usually with the surface modem set to a slower bitrate.

Master Retries

In the case of *Data* transmission sub-frames not successfully received following a request for data, the requesting modem can re-request specific failed sub-frames. This feature allows the data bitrate to be increased without loss of connectivity.

This is set via the *Master Retries (MR)* parameter (not to be confused with the *MR* or *Measure Range* command) using the *MS* command (see Section 15.2). It is set to an appropriate value by default and should not require alteration.

13.2. Sonardyne Debugger

Discovery offers a useful tool for troubleshooting called “Sonardyne Debugger”. It allows to test the functionalities of the acoustic modem.

In Discovery select the Aquarius and click on **Tools** → **OBS** → **Sonardyne Debugger** to launch the interface.

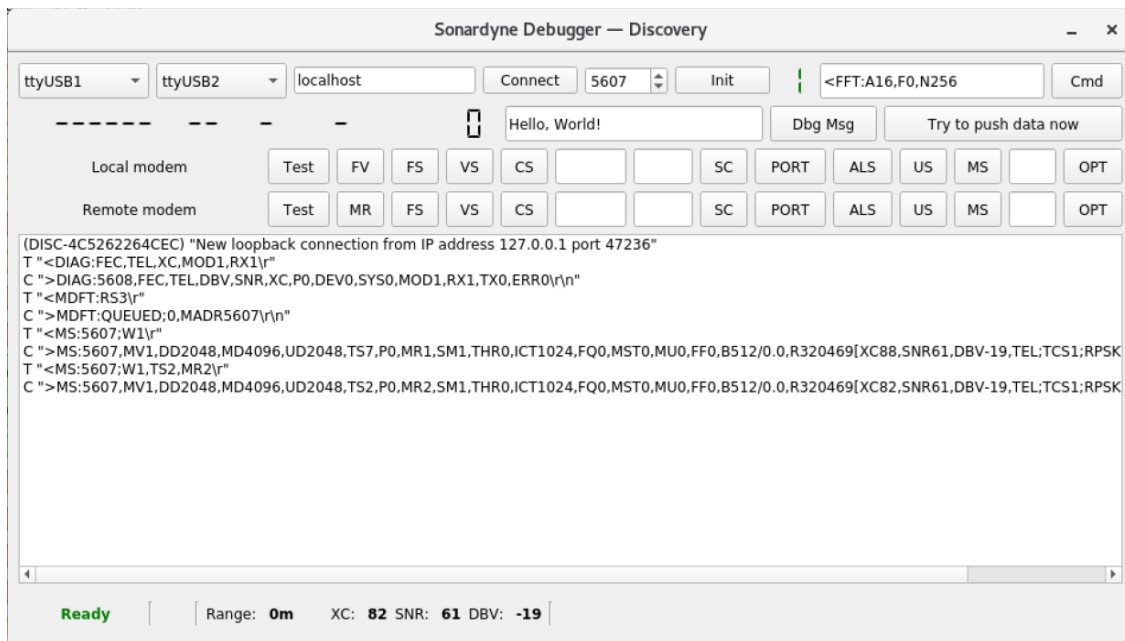
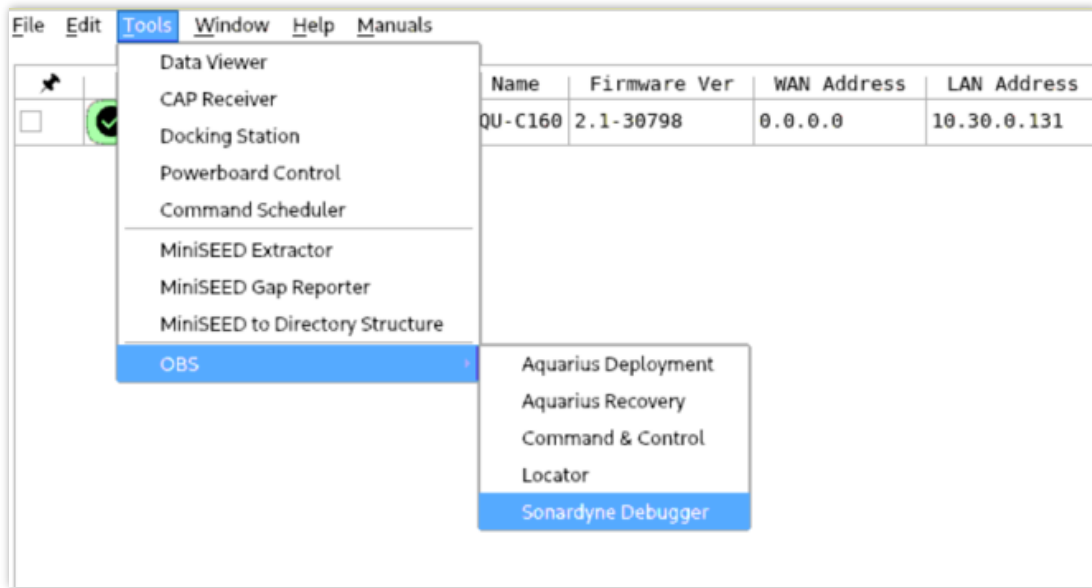

The top section of the window is used to establish the serial connection to the modem and the TCP/IP connection to the Discovery physically connected to the modem. The following

Aquarius Ocean Bottom System

screenshot shows a configuration in a Discovery in a deck unit, so connected by serial to the surface modem. The hostname used in this case is "localhost". Press the "Connect" button to establish a connection to the local Discovery at IP 127.0.0.1. Wait for the status at the bottom-left of the window to be **Ready**.

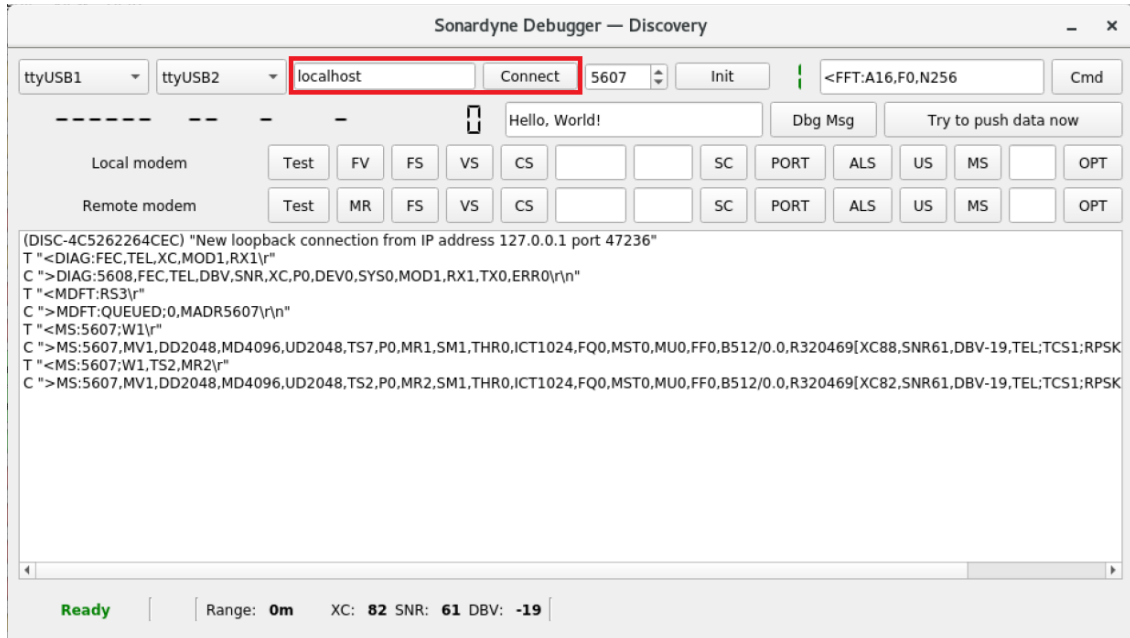

Use the drop-down menus at the top-left to select the PC serial ports connected to the "Command" and "Data" ports of the surface modem. These ports are used in the modem for console commands and data transmission respectively.

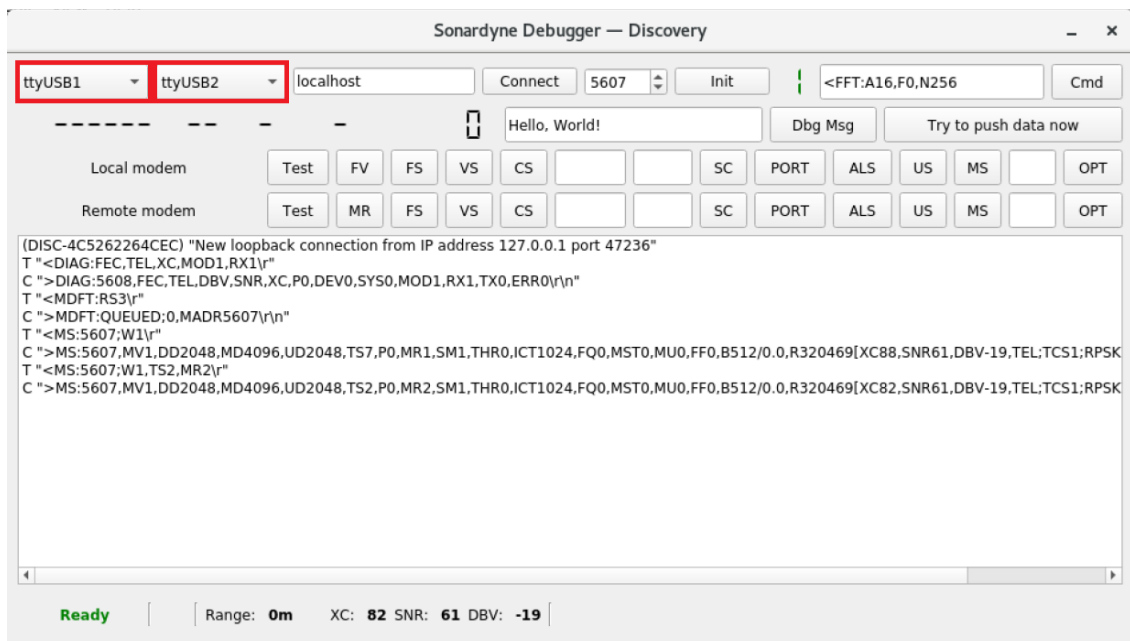

Note: In Windows use the Device Manager to determine the ports. In Linux use command `dmesg | grep ttyS` or `dmesg | grep ttyUSB` (in case you are using USB to serial converters) to show available ports.

The pre-selected ports are saved in the config.ini file.

In case of a Sonardyne Debugger in a remote Discovery, insert the WAN or LAN IP address of the PC where the Discovery, physically connected to the surface modem, is installed and click the "Connect" button. As shown in the screenshot below, both the serial ports drop down menu will be blanked.

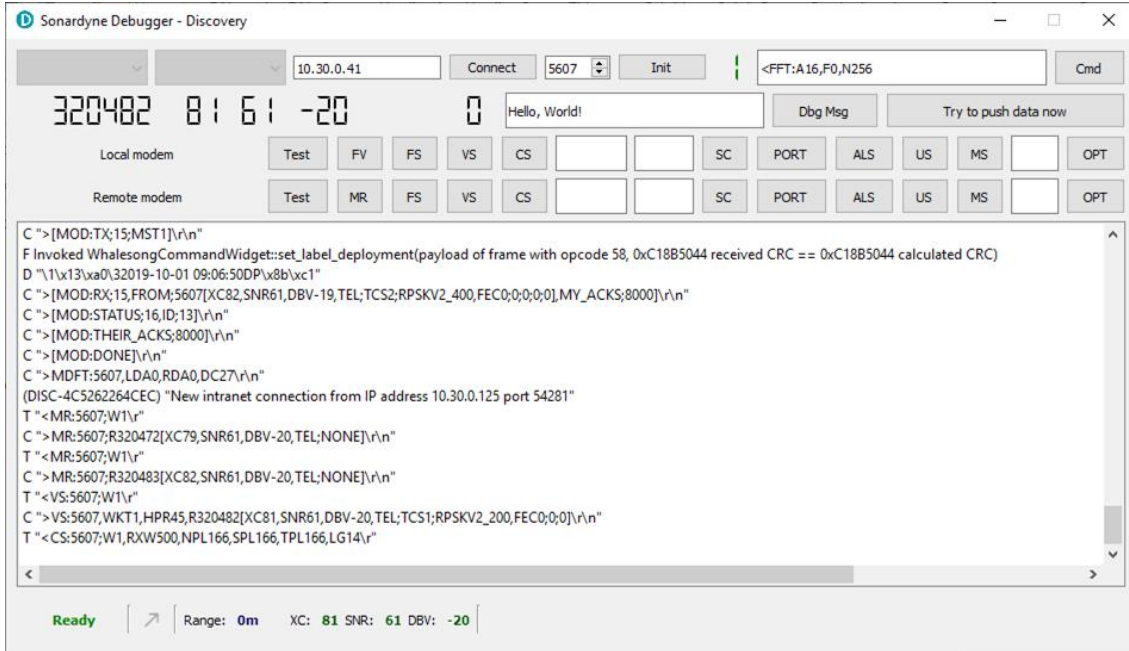

Type in the acoustic address of the remote acoustic modem.

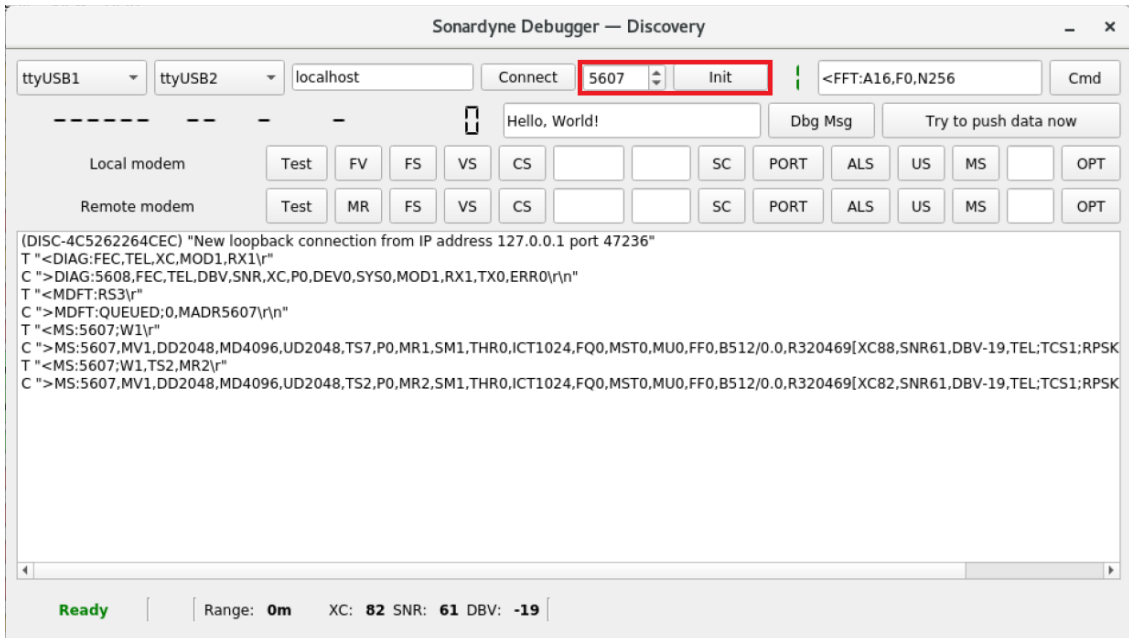

After this, press the **Init** button to initialise the surface acoustic modem. Only after these steps the end user can start sending commands.

Aquarius Ocean Bottom System

Manual commands can be sent using the field at the top-right. Click on **Cmd** button to send the command.

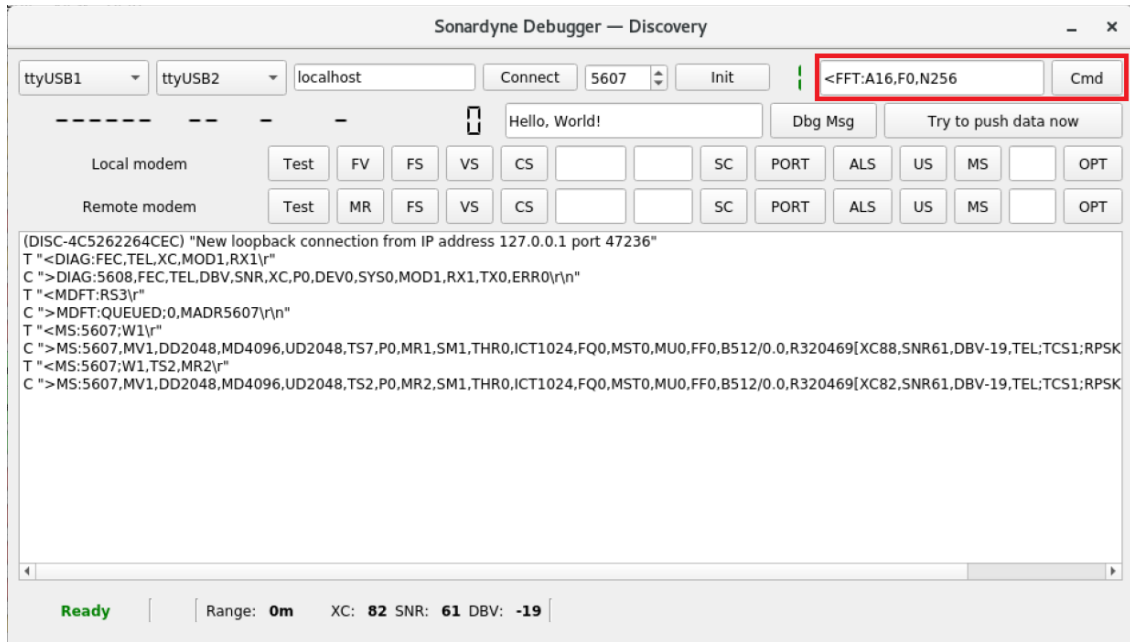

For quick access to most common commands use the buttons below:

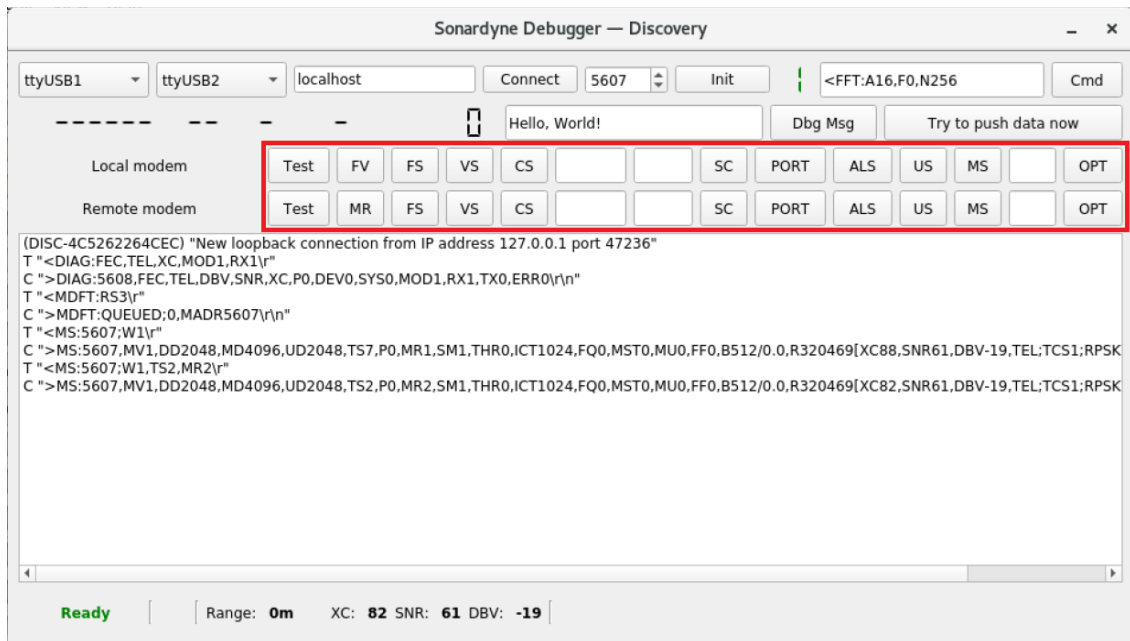

- MR: Measure Range.
- CS: Configuration Status.
- MS: Modem Status.



Note: The remaining buttons are used in the factory by the manufacturer for development reasons only.

Aquarius Ocean Bottom System

The bottom panel shows commands sent and received. Each line is marked with a letter that distinguishes the type of instruction:

- T: Command transmitted to the “Command” port.
- C: Answer from the surface modem received on the “Command” port.
- D: Data received on “Data” port.

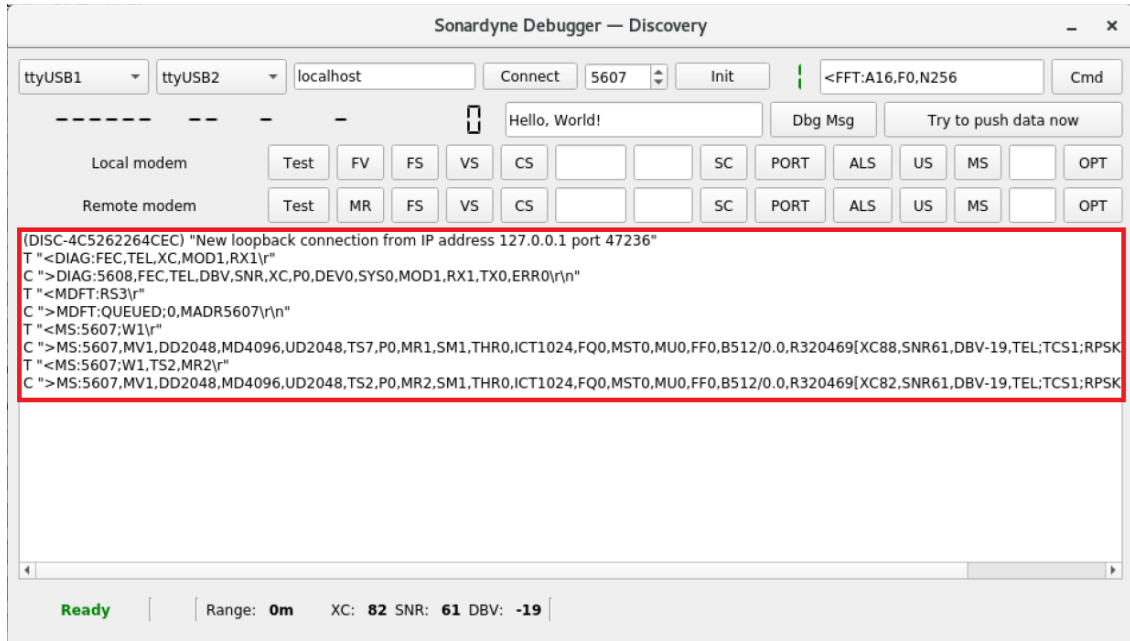

More details on console output are available in Section 15.3.

13.3. Troubleshooting

In the case of a suspected poor acoustic link, a methodical approach is required to ascertain the cause and any potential remedies. This section assumes that the *Bottom* modem is attached to a deployed OBS and the *Surface* modem is attached to a suitable deck/topside unit and suspended in water.

Before beginning to troubleshoot, first confirm that the *Surface* modem/transducer can be communicated with. To verify the connection to the *Surface* modem:

1. Ensure the acoustic modem driver IP address is correct (“localhost” if the *Surface* modem is physically connected) and click “Connect”. This connects to the driver which will directly interact with the acoustic modem. If the status bar indicates **Network Error**, then ensure the correct acoustic modem driver address before proceeding.
2. Ensure the serial port configuration for the two acoustic modem connections is correct (see Section 15.2).
3. Ensure the *Remote* acoustic modem address of the OBS modem is shown correctly in the remote modem address field. If it is not, correct it.

4. Click the “Init” button. This will initialise, or reinitialise, the *Local Surface* modem. At this point the status bar should display **Ready**. If it does not, verify all relevant physical connections, network connections, serial ports and addresses.

In order to confirm the operation of the *Surface* modem, set its power parameters to suitable for air and initiate acoustic transmissions. It should be possible to hear the transducer. If no audible signal can be detected from the *Surface* modem transducer, verify all relevant physical connections, power, network connections, serial ports and addresses.

If the *Surface* modem appears to operate correctly, lower it into the water to circa 10 meters and attempt to communicate with the OBS *Bottom* modem.

13.3.1. Send a Short Command

When a suspected acoustic transmission problem occurs, start by attempting to send a short and simple *Command*. These are significantly more likely to succeed than *Data* transmissions.

The *MR* command (Measure Range) is recommended as the shortest and most likely acoustic transmission to successfully complete a round trip. This removes dependence on correctly set *Modem Status* Parameters (including *TS*, *DD*, *MD*, *ICT* and *UD*) and simplifies configuration efforts to *Configuration Status* Parameters (such as *SPL*, *TPL*, *LG* and *RXW*). *MR* is not the sole *Command* that serves this purpose.

A *MR* command can be sent from the *Sonardyne Debugger* found in Discovery (see Section 13.2). It can be sent by typing the following command string into the custom command field:

```
<MR:aaaa;W1
```

[where *aaaa* is the *remote modem acoustic address* of the node you are attempting to communicate with]

Alternatively, for convenience, the *Remote* modem “MR” button is provided in the *Sonardyne Debugger* interface to send an *MR* command to the *Remote Modem Address* set and initialised in the *Local* acoustic modem driver.

If successful, the *MR* command will return with the round-trip time (in microseconds) as a parameter:

```
>MR:aaaa;R123456
```

If you do not receive a response containing a valid, non-zero, round-trip time, then the *MR* command has failed (even if no explicit error is given).

It is possible that the recipient modem may be in a low power sleep mode. If this is the case, the very first (and only the first) *Command* sent may fail. The addition of *w1* in a command instructs the modem to wake up.



Note: Early versions of Discovery do not correctly parse acoustic diagnostic/status information from received *MR* commands. In this case the *VS*

command should be used for debugging. The *VS* command can be sent using the *Modem Ping* button in the *Post-Deploy* tab of *OBS Command & Control* widget.

Command Failure

If this lightweight *Command* has failed to yield a successful reply, the *TPL*, *SPL*, *NPL*, *LG*, and *RXW* parameter values should be verified as correct for the deployment depth.

If the acoustic link state of health bar at the bottom of the *Command & Control* window (or elsewhere) is displaying recent values for *SNR* and *DBV*, these can indicate whether the depth related parameters require alteration. It also implies that the *Bottom* modem is receiving a transmission and responding. If *DBV* is high, this indicates the transmission power of the *Bottom* modem is too high or the *LG* of the *Surface* modem is too high, or both. These can be changed with the *Depth Configuration* section in the *Acoustic Configuration* tab of the *Command & Control* window. Experiment by changing parameters in the *Remote/Bottom* or *Surface/Local* modems individually and, if necessary, change the parameters in both.



Note: Assuming that before the deployment the bottom modem was correctly configured from the LPC webpage, we recommend trying to fix the communication issues, trying first to change the parameters in the surface modem. This will avoid risking increasing the power consumption in the OBS or to compromise permanently the acoustic link (thing that could happen if by mistake a too shallow setting is chosen, bringing *LG* parameter too low).

If the acoustic link state of health bar indicates low signal *DBV* or does not indicate any recent state of health information, then it is likely that the depth related parameters are set too shallow. Experiment by increasing the depth configuration in the *Remote/Bottom* or *Surface/Local* modems individually and, if necessary, change the parameters in both.

In the case where *DBV* acoustic diagnostic values appear to be healthy, yet *SNR* values appear low, it is possible that noise from the ship is interfering. Try to lower the *Surface* modem lower to reduce noise or move to a less noisy area of the ship (i.e. far from the engine), or if other acoustic devices are on, ask to switch them off.

If, after increasing/decreasing depth parameters in both modems, it is still not possible to successfully send and receive an *MR* (or other lightweight) *Command*, it is likely that the distance between the two modems is too great. If the depth of the OBS is not believed to be the problem, then the lateral distance away from the position of the OBS is likely to be the cause. All acoustic modem transducers have an operating cone ($\pm 40^\circ$ for the directional transducers, $\pm 120^\circ$ for the omnidirectional transducers), outside of which their effectiveness is diminished. Attempt to move closer to the OBS and retry.



Note: The maximum permissible lateral distance between acoustic modems depends on depth; the deeper the water the further the lateral distance may be, the shallower the water the closer they must be. Always try to position a vessel as close to the estimated position of the OBS as possible.

13.3.2. Read Modem Status

If a lightweight *Command* is successfully transmitted and received, then the next step is to obtain more detailed information from the *Bottom* acoustic modem. This will further test the viability of the acoustic link whilst still limiting the range of relevant configuration parameters.

From the *Sonardyne Debugger* window, send a request for the *Configuration Status* parameter values by either clicking the *Remote* modem “CS” button, or sending the following *Command*:

```
<CS:aaaa;W1
```

[where *aaaa* is the *remote modem address* of the node you are attempting to communicate with]

Correct responses will follow this format:

```
>CS:aaaa,TATnnn,BLKnnn,RXWnnnn,TXWnnn,NPLnnn,TPLnnn,LGnn,CISn,ATn,
  ECn,ME n,RSPn,PPRn,Rnnnnnnn
  [XCnn,SNRnn,DBV-n,TEL;TCSn;RPSKVn_nnn,FEC0;0;0]
```

Erroneous responses may contain “**NO_REPLY**”:

```
>CS:aaaa,NO_REPLY
```

This indicates that no acoustic signal was received from the other/*Bottom* acoustic node within the *Receiver Wait Time (RXW)*. It is not possible to infer whether the original transmission was received by the *Bottom* or whether the *Bottom* modem attempted to transmit. Therefore, the configuration of both acoustic modems must be investigated.

Erroneous responses may also contain “**NO_DATA**”:

```
>CS:aaaa,NO_DATA OR >CS:aaaa,TATnnn,NO_DATA,RXWnnnn,TXWnnn,etc...
```

In this case the *Bottom* acoustic modem has received the initial *CS* command and attempted to respond. However, the acoustic transmission from *Bottom* to *Surface* was not successful. The most likely cause is improper configuration of the *Bottom* acoustic modem.

The procedure for improving the strength of the acoustic link is the same as for the lightweight command example given above. Ensure that appropriate power, gain, *RXW* values are set in both modems.

13.3.3. Get OBS System Information

Aquarius Ocean Bottom System

If the previous troubleshooting procedures have succeeded, it is known that the acoustic link is strong enough to allow the two modem nodes to communicate. The parameters relevant to both *Command* and *Data* transmissions have been validated. From here, the next step is ensuring that the acoustic link is viable for transmitting longer *Data* frames. There is a subset of acoustic modem parameters that affect *Data* transmissions specifically.

From the *Post Deploy* tab of the *OBS Command & Control* window, click either the “Get Aquarius ID” or “Get SEED ID” buttons. These will send an *MDFT* frame with a request for data (the Host Name or the SEED network and station codes respectively). The requested information should be returned by the OBS system in an *MDFT* frame.



Note: The LPC of an Aquarius system may be asleep. Sending a *Data* transmission instructs the system to wake up, but the first *Data* transmission sent to a sleeping Aquarius system will not return any data

Following a successful “Get ID” operation, an identification string should be shown in the *Post Deploy* tab. If an ID is obtained, it is advisable to carry the operation a further 5 – 10 times to ensure that the acoustic link is performing adequately with minimal failed transmissions.

System Information Request Failure

If it not possible to retrieve a system identifier (or there is an unacceptable failure rate), then begin verifying relevant parameters. There are a number of acoustic modem parameters that directly impact on the success of *Data* transmissions.

If the preceding *Command* based troubleshooting procedures have been followed, *MDFT* “NO_REPLY” and “NO_DATA” responses should not occur. If they do, the preceding troubleshooting sections should be repeated to verify correct power, gain and Receiver Wait parameter values.

Successful *MDFT* response without data:

The *MDFT* transmission may complete successfully (as far as the modems are concerned) without transmitting the anticipated data payload. In the modem debugging window (*Sonardyne Debugger*) this would look like:

```
<MDFT:aaaa;W1
>[MOD:TX;15;MST1]
>[MOD:RX;15, FROM;5110
  [XC86, SNR15, DBV-11, TEL;TCS1;RPSKV2_100, FEC0;0;0;0;0]
  ,MY_ACKS;8000]
>[MOD:STATUS;16, ID;11]
>[MOD:THEIR_ACKS;8000]
>[MOD:DONE]
>MDFT:5110, LDA0, RDA0, DC0
```

Here the transmission completes without any acoustic link errors, but identifying information may not be shown in the *Post Deploy* tab.

Aquarius Ocean Bottom System

In this case, it is likely that the *Remote Bottom* modem attached to the OBS is not waiting long enough for the OBS system to process and collate the data payload before the modem send its response.

In this case it is necessary to increase one or more Local Modem Delays (*DD, UD, MD* or *ICT*) to force the *Bottom* modem to give enough time to the OBS to process a request for data.

The correct Local Modem Delay parameter values depend on the data processing operation that the OBS must carry out. They should be set correctly from factory and should not require alteration. If they require alteration, contact Güralp in the first instance.

If it is not possible to contact Güralp, then trial and error should be employed to identify which Local Modem Delay parameter value requires alteration. Increase each delay parameter in turn by single steps as required to regain communication with the OBS.

MDFT response missing subframe:

The *MDFT* command may be received by the OBS *Bottom* modem and subsequently by the *Surface* modem, however the data payload may be lost. This would look like the following in the modem debugging window:

```
<MDFT:aaaa;W1
>[MOD:TX;15;MST1]
>[MOD:RX;NO_DATA[XC98,SNR15,DBV-11,TEL;TCS1;RPSKV2_100,
  FEC0;0;-1;0;0]]
>[MOD:RX;NO_REPLY[XC0,SNR0,DBV0,TEL;NONE]]
>[MOD:STATUS;16,ID;11]
>[MOD:THEIR_ACKS;8000]
>[MOD:DONE]
```

Here the modems can communicate *Commands* but struggle to transmit payload data.

Assuming that correct parameters values for power, gain and receiver wait have been set in the previous troubleshooting procedures; it is most likely that the data bitrate is set too high for the deployment scenario. The *Telemetry Scheme (TS)* parameter should be reduced in single steps until the *MDFT Data* transmission is reliably successful.

If *TS* is set to the lowest setting but data transmission is still failing, revisit earlier troubleshooting steps to validate other modem parameters.

13.3.4. Get Seismic Data

The most arduous test of the acoustic link is the transfer of seismic data from OBS to the surface. Seismic data is retrieved as individual 4 KiB miniSEED records.

Using one of the methods outlined in this manual, identify and attempt to retrieve a miniSEED record. If successful, the following can be observed in the modem debugging window:

```
<MDFT:aaaa;W1
>[MOD:TX;15;MST1]
```

Aquarius Ocean Bottom System

```
>[MOD:RX;15,FROM;5110[XC98,SNR18,DBV-8,TEL;TCS1;HDR_SE_3500,
  FEC0;0;0;0;0;0;0;0;0;0;0;0;0;0;0;0],MY_ACKS;8000]
>[MOD:RX;14,FROM;5110[XC97,SNR18,DBV-8,TEL;TCS1;HDR_SE_3500,
  FEC0;0;0;0;0;0;0;0;0;0;0;0;0;0;0;0],MY_ACKS;C000]
>[MOD:RX;13,FROM;5110[XC98,SNR18,DBV-8,TEL;TCS1;HDR_SE_3500,
  FEC0;0;0;0;0;0;0;0;0;0;0;0;0;0;0;0],MY_ACKS;E000]
>[MOD:STATUS;16,ID;10]
>[MOD:THEIR_ACKS;8000]
>[MOD:DONE]
```

The number of frames and sub-frames required to transmit 4 KiB depends on the value of the *Telemetry Scheme* parameter; the higher the *TS* value, the fewer sub-frames required.

At the end of the *Data* transmission, the data viewer window should open to display the seismic data.

Seismic Data Transmission Failure

If the data viewer window fails to open, it is likely that one or more sub-frames were lost leading to an incomplete miniSEED record. This can be confirmed in the modem debugger window with the presence of:

```
>[MOD:RX;NO_DATA[XC98,SNR15,DBV-11,TEL;TCS1;RPSKV2_100,
  FEC0;0;-1;0;0]]
```

And/or:

```
>[MOD:RX;NO_REPLY[XC0,SNR0,DBV0,TEL;NONE]]
```

FEC is the number of telemetry code symbol errors corrected by the forward error correction algorithm. *-1* indicates that the correction power has been exceeded, so the error could not be corrected. The number of reported *FEC* values and the number of correctable errors is dependent on the telemetry type.

FEC values <4 are indicating a reasonable acoustic link, while *FEC* values between 4 and 6 are indicating a difficult acoustic link.

The number of permitted dropped sub-frames depends on the value of the *Modem Retries* or *MR* parameter. The higher the value for *MR*, the more sub-frames may be dropped with a successful data transfer.

In any case, the procedure for reducing the number of missing sub-frames is the same as the case of short *Data* transmissions. Revisit the previous section, or prior sections if necessary, to verify correct parameter values. Starting by lowering *TS* in the bottom modem.

14. Appendix D – Detailed Checklist

Pre-deployment:

Aquarius name:	Aquarius S/N:
Location name:	Deployment date/time (UTC):
Latitude:	Longitude:
Depth (m):	Acoustic modem address:
LPC firmware:	ULPD firmware:
Release time (deck):	Release time (post-deploy):

At recovery:

Recovery date/time (UTC):	
Latitude:	Longitude:
Time offset:	

14.1. OBS Assembly Check

OBS assembly checks are performed to verify that all mechanical components of the Aquarius are correctly installed and secured. These checks confirm the integrity of the battery installation, buoyancy, lifting frame, ballast attachment, burn-wire system, and corrosion protection. The table below summarises the assembly checks that must be completed before deployment.

Action	Details	Section	Check
Battery checked	Battery fully (or adequately) charged	5	
	Charger pressure cap re-attached		
Lifting frame attached	Lifting frame attached	4.13	
Aquarius mounted on ballast	Straps inserted in two opposite slots	6.1.1	
	Aquarius protruding inner rim aligned with ballast inner circle		
	Aquarius rotationally aligned with slots		
	Straps placed into burn-wire arms	6.1.2	

Burn-Wire system assembled	Arms tensioned with tensioning tool		
	Burn-wire put into place		
	Tensioning tool removed		
Magnetic off plug removed	Magnetic off plug removed	4.12	
Sacrificial anodes installed	2 vent caps with O-rings on the top of Aquarius canister		
	2 on lifting frame		
	1 on each release arm (total = 2)		
	1 on modem cage		

14.2. Aquarius Webpage Configuration Checks

The Aquarius is configured primarily through the LPC embedded webpage. The configuration can then be exported using the Discovery software for archiving. The table below summarises the configuration checks that should be completed prior to deployment, including the relevant parameters and where they can be verified.

Area	Details	Interface	Section	Check
Station Metadata	Network Code set	Webpage – <i>Network</i> tab	8.3	
	Station Code set			
Timing Source	PTP override GPS configured	Webpage – <i>Network</i> tab	8.4	
	Master found	Webpage – <i>Status</i> tab		
	PTP locked			
Low battery thresholds	Hibernate threshold set	Webpage – <i>Setup</i> tab	8.6	
	Release threshold set			
Data Stream	1CVDAC and IPLL00 enabled (5 Hz)	Webpage – <i>Data Stream</i> tab	8.7	
Data Record	FR channels enabled	Webpage – <i>Data Record</i> tab	8.8	
	Non-FR channels disabled			
Configuration	Config file downloaded	Discovery Software	8.9	

14.3. Acoustic Communication Checks

Pre-deployment acoustic communication checks are performed using the *OBS Command & Control* tool within the Discovery software. These checks confirm that the acoustic modem is correctly configured and that reliable communication with the Aquarius can be established prior to deployment. The table below summarises the acoustic configuration and communication checks to be completed.

Area	Details	Interface	Section	Check
Acoustic configuration	Deployment depth set	OBS Command & Control tool – <i>Acoustic Configuration</i> tab	9.1.2	
Modem communication	Modem range successful	OBS Command & Control tool – <i>Post-Deploy</i> tab	9.1.3	
	Modem ping successful			
Aquarius communication	Aquarius ID obtained	OBS Command & Control tool – <i>Post-Deploy</i> tab		
	SEED ID obtained			

14.4. Pre-Deployment Checks

Pre-deployment checks are performed using the *Aquarius Deployment* tool within the Discovery software. These checks confirm that the system is correctly configured, PTP-synchronised, and ready for deployment. The table below summarises the final verifications that must be completed before deploying the Aquarius.

Area	Details	Interface	Section	Check
System Reset	System Reset performed	Aquarius Deployment tool – <i>System Reset</i> tab	9.2.1	
Web Interface	PTP set as timing source	Aquarius Deployment tool – <i>Web Interface</i> tab	9.2.2	
	Local modem address noted			
	Deployment depth set			
	Recording taps verified			
	Battery status adequate			
Timing	PTP 100% Locked	Aquarius Deployment tool – <i>Timing</i> tab	9.2.3	
	Offset 0 ms			
Storage	SD cards formatted	Aquarius Deployment tool – <i>Storage</i> tab	9.2.4	
	SD cards recording			

Recovery tools	Burn-Wire voltage checked (from ULPD - backup method)	Aquarius Deployment tool – <i>Recovery</i> tab	9.2.5	
	Backup recovery time set			
Deployment mode	Deployment mode activated after all checks are performed	Aquarius Deployment tool – Deploy button	9.2.6	

14.5. Deployment Procedure Check

The deployment procedure is carried out using the *Aquarius Deployment* tool and *the OBS Command & Control* tool within the Discovery software. This procedure places the system into deployed mode and confirms correct operation during deployment and descent. The table below summarises the key deployment actions to be performed.

Area	Details	Interface	Section	Check
Deployment mode	Deploy button clicked	Aquarius Deployment tool – Deploy button	9.2.6	
Cables disconnection	Ethernet and serial cable disconnected from OBS top lid			
Caps in place	SubConn 13-way connector dummy cap placed			
	Locking sleeve screwed down			
	All caps properly screwed down with O-rings in place			
Acoustic check in deployed mode	Modem range successful	OBS Command & Control tool – <i>Post-Deploy</i> tab	9.1.3	
	Modem ping successful			
	Aquarius ID obtained			
	SEED ID obtained			
Recovery aids test and activation	Burn-Wire voltage checked (via acoustics - primary method)	OBS Command & Control tool – <i>Recovery</i> tab	9.1.6	

	Apollo beacon activated with magnet switch			
Position instrument	Aquarius moved in deployment position			
Deploy Aquarius	Aquarius is in the sea and sinking			

14.6. Post-Deployment Checks

The post-deployment checks are performed using the *OBS Command & Control* tool and the Discovery software once the Aquarius has reached the seabed. These checks confirm successful communication, correct centring, data acquisition, and overall system performance. Once the Aquarius is on the seabed, a location survey can be performed using the *Locator* tool. The table below summarises the post-deployment actions to be carried out.

Area	Details	Interface	Section	Check
Status	Status requested and pressure increasing	OBS Command & Control tool – <i>Post-Deploy</i> tab	9.1.3	
Acoustic check while descending and on the seabed	Modem range successful			
	Modem ping successful			
	Aquarius ID obtained			
	SEED ID obtained			
Centring status	Centring completed			
Release time	Release time updated			
Location survey	Aquarius location determined	OBS Locator tool	9.3	

14.7. Recovery Procedure Check

This section describes the checks to be performed after recovery of the Aquarius to confirm correct system operation and ensure successful data retrieval. The *OBS Command & Control* tool is used to release the ballast, the *Aquarius Recovery* tool is used check time offset and force a data flush, the webpage is used to complete the undeployment and download the data. The required recovery checks are listed in the table below.

Aquarius Ocean Bottom System

Area	Details	Interface	Section	Check
Ballast release	Ballast release triggered	OBS Command & Control tool – <i>Recovery</i> tab	9.2.5	
Status	Status requested and pressure decreasing	OBS Command & Control tool – <i>Post-Deploy</i> tab	9.1.3	
Aquarius recovery	Aquarius located on the sea surface			
	Aquarius on boat			
Aquarius communication	Aquarius connected to deck unit using Ethernet cable			
	PoE switched on			
Aquarius undeployment	PTP locked 100%	Aquarius Recovery tool	9.4	
	Time offset written down			
	Data flushed to SD cards			
	First system reset performed			
	Recording stopped	Webpage – <i>Setup</i> tab	8.11	
	Aquarius undeployed			
	Second system reset performed			
Data recovery	Data downloaded	Webpage – <i>Storage</i> tab	10	

15. Appendix E – Printable Checklist

Aquarius name:	Aquarius S/N:
Location name:	Deployment date/time (UTC):
Latitude:	Longitude:
Depth (m):	Acoustic modem address:
LPC firmware:	ULPD firmware:
Release time (deck):	Release time (post-deploy):

Recovery date/time (UTC):

Latitude: Longitude:

Time offset:

(1) OBS assembly
Battery fully (or adequately) charged
Charger pressure cap re-attached
Lifting frame attached
Straps inserted in two opposite slots of the ballast
Aquarius protruding inner rim aligned with ballast inner circle
Aquarius rotationally aligned with slots
Straps placed into burn-wire arms
Arms tensioned with tensioning tool
Burn-wire put into place
Tensioning tool removed
Magnetic off plug removed
2 vent caps with O-rings on the top
2 on lifting frame
1 on each release arm (total = 2)
1 on modem cage

(2) Webpage configuration
Network and Station codes set
PTP configured: master found and PTP locked
Hibernate and release thresholds set
Streaming channels "1CVDAC" and "1PLLO0" enabled at 5 Hz
Recording FR channels enabled
Non-FR channels disabled
Config file downloaded

(3) Pre-deployment acoustic checks
Deployment depth set
Modem range successful
Modem ping successful
Aquarius ID obtained
SEED ID obtained

(4) Aquarius Deployment tool
System Reset
Web Interface
Timing
Storage
Recovery tools
Deployment mode activated

(5) Deployment Procedure
Ethernet and serial cable disconnected from OBS top lid
SubConn 13-way connector dummy cap placed
Locking sleeve screwed down
All caps properly screwed down with O-rings in place
Acoustic checks repeated
Burn-Wire voltage checked
Apollo beacon activated with magnet switch
Aquarius moved in deployment position
Aquarius is in the sea and sinking

(6) Post-deployment checks
Status requested
Acoustic communication successful while descending
Acoustic communication successful on seabed
Centring completed

(7) Recovery Procedure
Ballast release triggered
SubConn 13-way connector dummy cap placed
Status requested and pressure decreasing
OBS located and carried on boat
OBS connected to deck unit (Ethernet cable)
PoE switched on
PTP locked 100%
Time offset written down
Data flushed to SD cards
First system reset performed (via Aquarius Recovery tool)
Recording stopped and Aquarius undeployed
Second system reset performed (via webpage)
Data downloaded

16. Appendix F – Glossary

- APG** : Absolute Pressure Gauge
- CS** : Configuration Status
- DBV** : Degree of Voice Breaks
- DD** : Data Delay
- DHCP** : Dynamic Host Configuration Protocol
- FEC** : Forward Error Correction
- GPS** : Global Positioning System
- HDPE** : High-Density Polyethylene
- ICT** : Inter Character Time
- IP** : Internet Protocol
- LAN** : Local Area Network
- LED** : Light-Emitting Diode
- LG** : Linear Gain
- LMF** : Lower Medium Frequency
- LPC** : Low Power Computer
- LTA** : Long Term Average
- MD** : Modem Delay
- MDFT** : Modem Data Frame Transfer
- MEMS** : Micro-Electro-Mechanical System
- MPPT** : Maximum Power Point Tracking
- MR** : Master Retries
- MR (command)** : Measure Range
- MS** : Modem Status
- NPL** : Navigation Power Level
- OBS** : Ocean Bottom System
- PoE** : Power over Ethernet
- PTP** : Precision Time Protocol
- RAM** : Random-Access Memory
- ROV** : Remotely Operated underwater Vehicle
- RXW** : Receiver Wait

Aquarius Ocean Bottom System

SBC : Single Board Computer

SoH : State of Health

SPL : Start Power Level

SNR : Signal to Noise Ratio.

STA : Short Term Average

TAT : Turn-Around-Time

TPL : Telemetry Power Level

TS : Telemetry Scheme

UD : Uplink Delay

UID : Unique Identification

ULPD : Ultra Low Power Digitiser

XC : Cross Correlation

17. Revision history

A	07/12/2020	Initial Release
B	10/08/2021	System/ballast assembly procedure added
C	20/08/2021	References tidied up
D	13/01/2025	General review and editorial improvements; Added checklists (Appendix D and E); Updated for Discovery v2; Screenshots and functionalities updated to firmware version 2.1-16189